

DB, DD & DX MOTOR-MATE KIT C-FACE ADAPTER ASSEMBLY INSTRUCTIONS

Install magnet assembly on the motor shaft with the setscrew in line with the shaft keyway. Turn the setscrew clockwise with the hex wrench furnished so that the setscrew protrudes into the keyway but is not tight. Install the motor adapter and tighten the 4 bolts. With the shaft held in the "extended" position if necessary, slide the magnet assembly forward until it touches the magnet depth gage.

Tighten the setscrew against the flat bottom of the keyway taking care that the magnet's position touching the gage does not change. Remove the gage and install the pumphead with the screws furnished.

IMPORTANT  MOTOR ROTATION MUST BE CLOCKWISE WHEN LOOKING AT THE MOTOR SHAFT. STANDARD TUTCAL PUMPS CAN BE DAMAGED BY EXTENDED OPERATION IN REVERSE ROTATION.

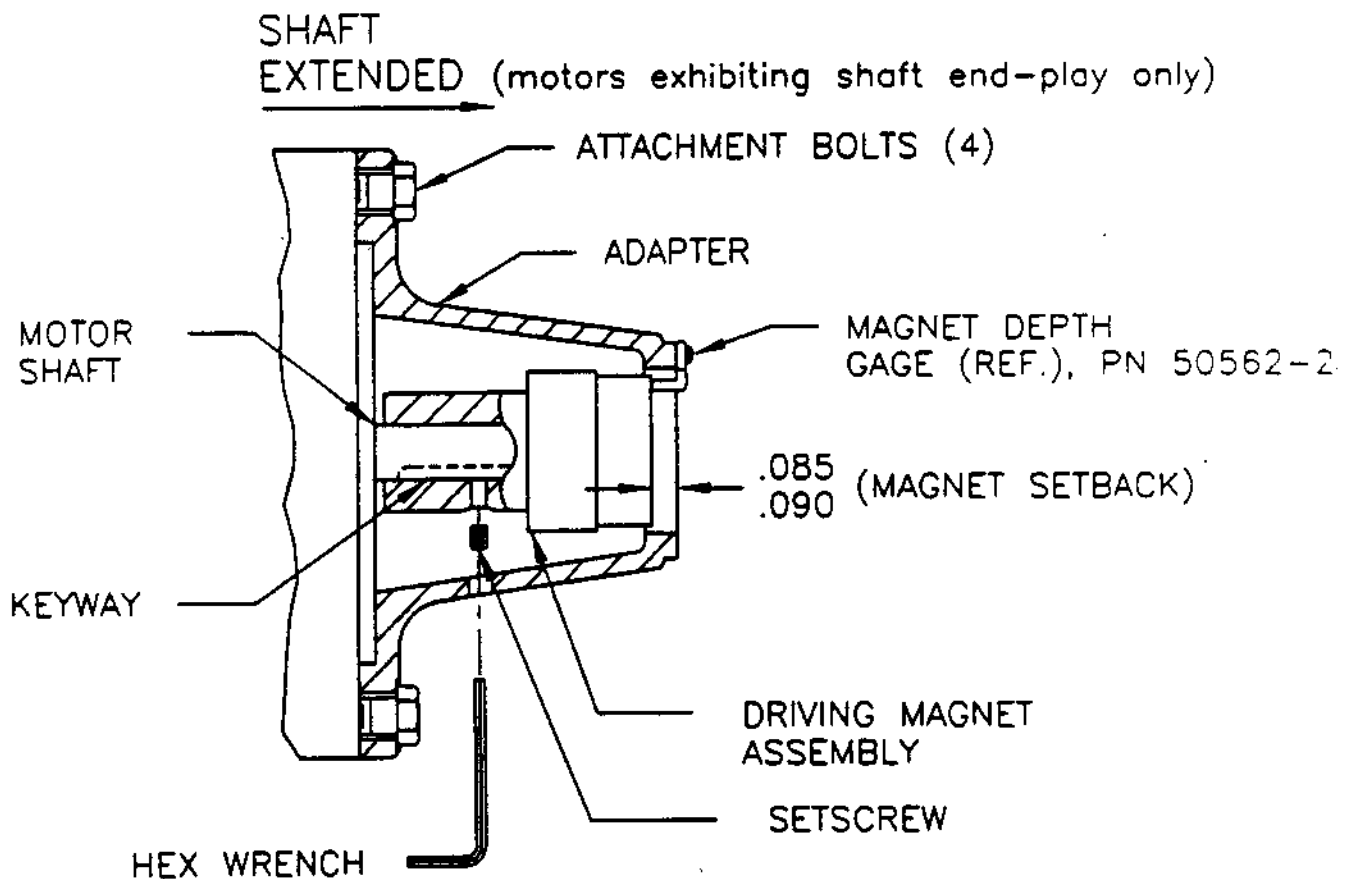

DN7001DC#2

PN 70010-1



TUTHILL
CORPORATION

Tuthill Pump Co.
of California

5143 Port Chicago Highway
Concord, California USA 94520
Tel 510 876-8000 Fax 510 876-815