

# **EPM**

ELECTRONIC PRECISION METERING

## ***P100 Metering Pump***

***Installation & Service***

***P100-991-2400A***



***Hydra-Cell***  
SIMPLY BUILT TO LAST

**WANNER ENGINEERING, INC.**

***Metallic Pump shown (Motor Optional)***

1204 Chestnut Avenue, Minneapolis, MN 55403  
TEL: (612) 332-5681 FAX: (612) 332-6937  
TOLL-FREE FAX [US only]: (800) 332-6812

www.epmpump.com  
email: sales@wannereng.com

# P100 Contents

	Page
Specifications.....	2
Dimensions .....	4
Installation.....	5
Maintenance.....	7
Fluid End	
Service .....	8
Parts List .....	10
Hydraulic End Parts List .....	12
Reducer/Base Assembly .....	13
Troubleshooting.....	14
Replacement Parts Kits .....	15

## Component Identification

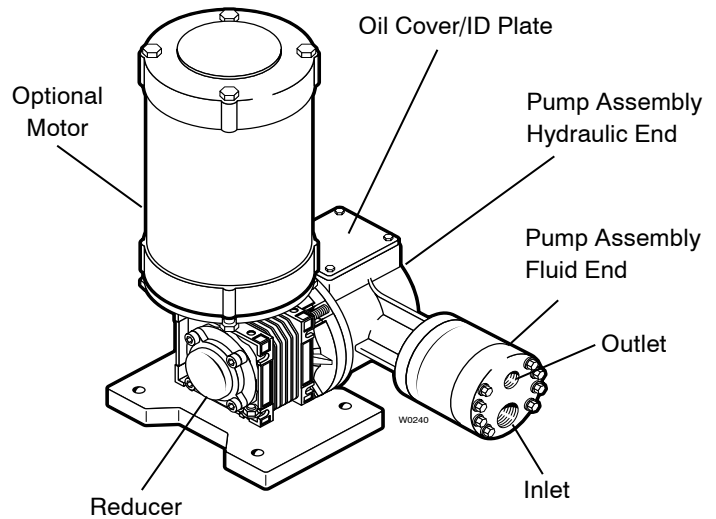

# P100 Specifications

### Steady State

**Accuracy** ±1%

### Max Pressure

Metallic Head: 1500 psi (104 bar)  
 Non-Metallic Head: Polypropylene: 250 psi (17 bar)  
 Kynar: 350 psi (24 bar)

### Capacity @ 100 PSI (7 bar) Discharge Pressure\*

RPM	GPH	LPH
120	4.4	16.66
240	8.7	32.93
360	13.2	49.97
480	17.5	66.24
720	26.5	100.3

**Max Inlet Pressure** 250 psi (17 bar)

### Max Temperature

Metallic Head: 250°F (121°C) – consult factory for temperatures above 160°F (71°C)  
 Non-Metallic Head: 140°F (60°C)

**Inlet Port** 1/2 inch NPT, BSPT

**Discharge Port** 3/8 inch NPT, BSPT

**Shaft Rotation** Bidirectional

**Oil Capacity** 1/8 US quart (0.12 liters)

### Weight

Metallic Head: 18.5 lbs (8.4 kg)  
 Non-Metallic Head: 16.4 lbs (7.4 kg)

## Motor Horsepower (kW)\*

RPM	≤500 (35)	≤1000 (70)	≤1500 (104)
120	1/4 (0.18)	1/4 (0.18)	1/4 (0.18)
240	1/4 (0.18)	1/4 (0.18)	1/4 (0.18)
360	1/4 (0.18)	1/4 (0.18)	1/2 (0.37)
480	1/4 (0.18)	1/2 (0.37)	1/2 (0.37)
720	1/4 (0.18)	1/2 (0.37)	3/4 (0.55)

\* This chart is approximate. Contact Wanner Engineering to determine specific motor horsepower application requirements.

# P = pressure in PSI (bar)

\* Capacity data for pumps with elastomeric diaphragms. Consult factory for performance characteristics of pumps with PTFE diaphragms.

# P100 Specifications

## Capacity @ 120 RPM (max)\*

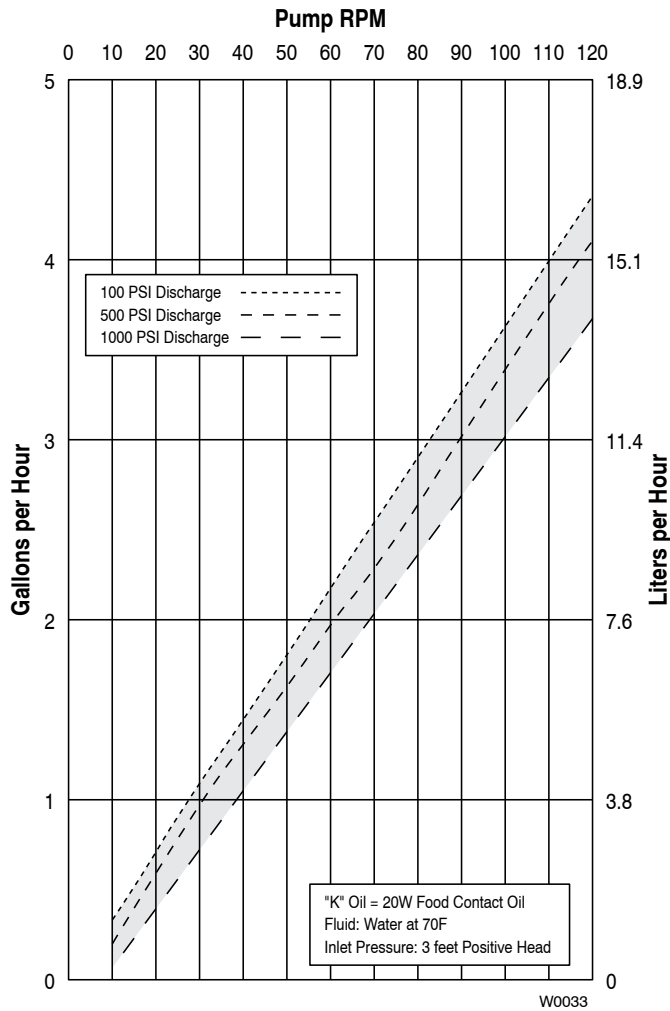

## Capacity @ 720 RPM (max)\*

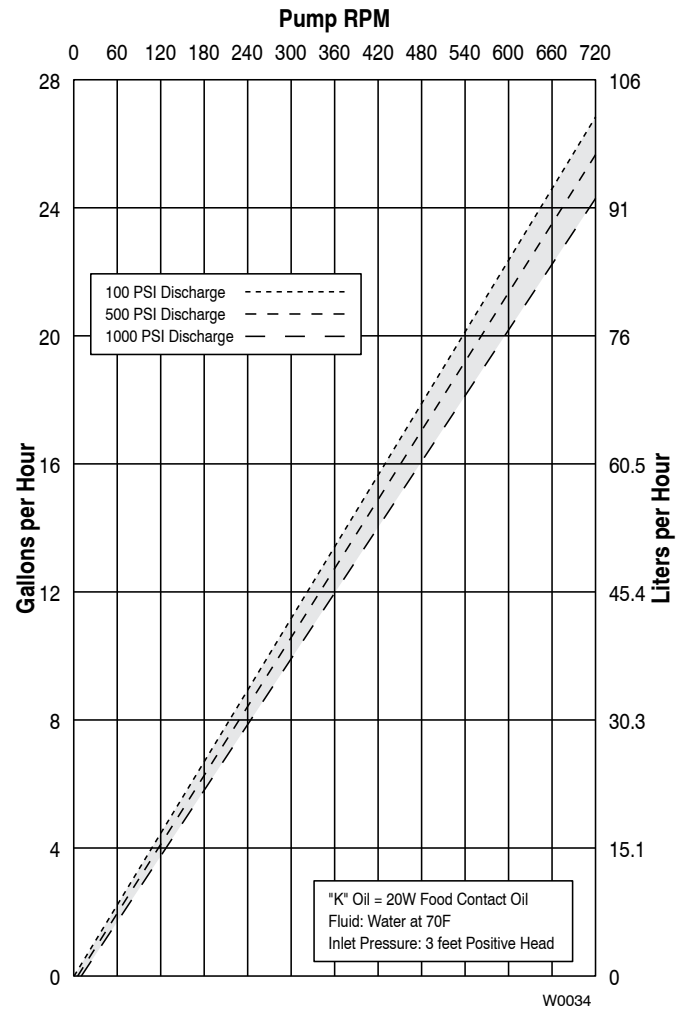

\* Capacity data for pumps with elastomeric diaphragms. Consult factory for performance characteristics of pumps with PTFE diaphragms.

Repeatability<sup>(1,2)</sup>:  $\pm 3\%$  of rated capacity over 10:1 turndown ratio.

Linearity<sup>(1,2)</sup>:  $\pm 3\%$  of rated capacity over 10:1 turndown ratio.

<sup>(1)</sup> Required pump discharge pressure equals 50 PSI (3.5 bar) minimum.

<sup>(2)</sup> Requires steady state discharge pressure.

# P100 Dimensions

## P100 Models with Metallic Pumping Head

316 Stainless Steel

Hastelloy® C

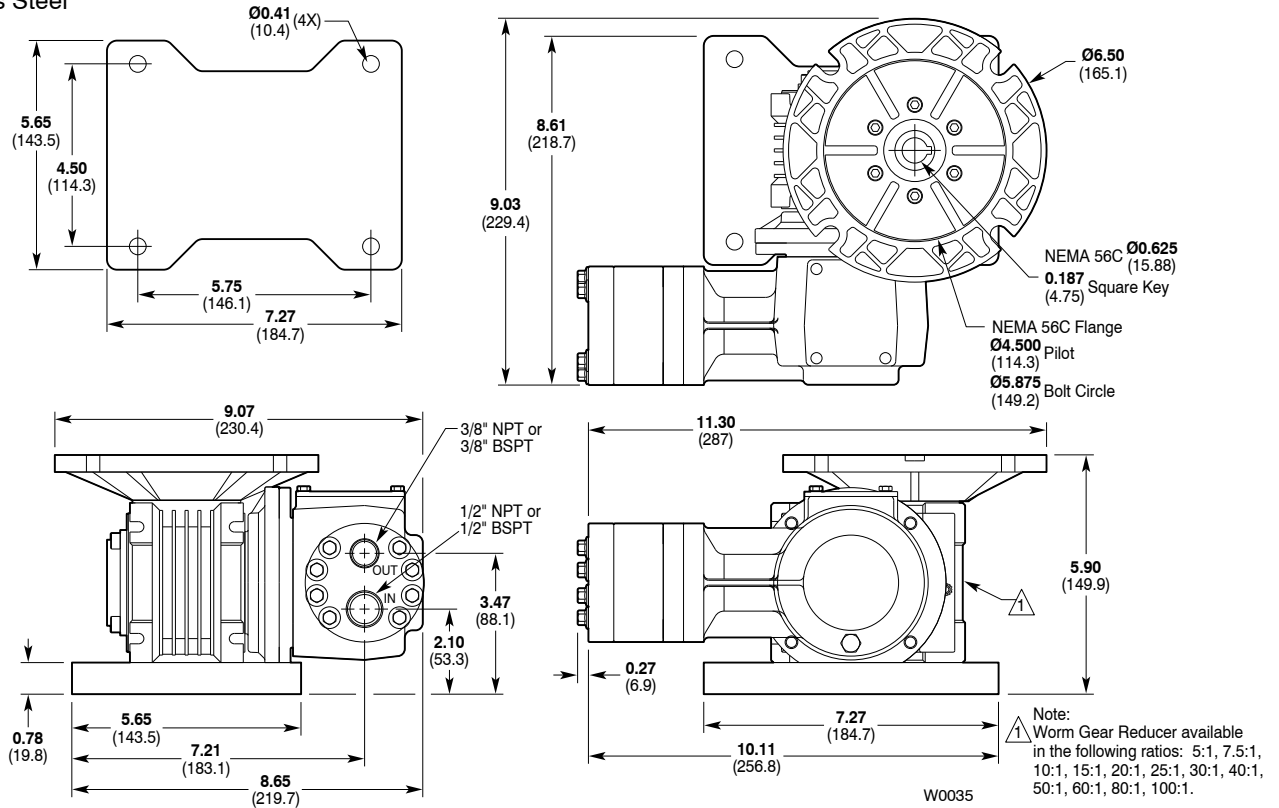

## P100 Models with Non-Metallic Pump Head

Kynar

Polypropylene

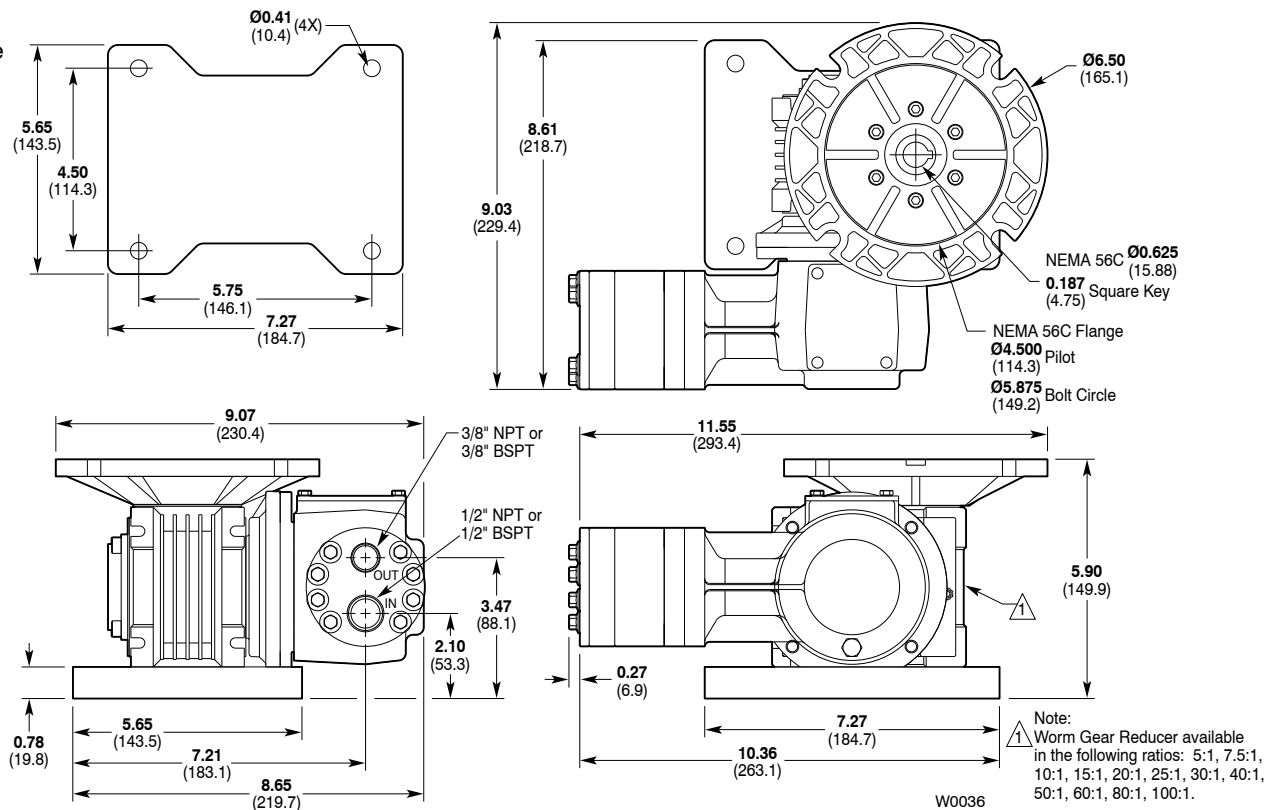

# P100 Installation

## Location

**NOTE:** The numbers in parentheses are Reference Numbers located in the Parts List exploded views of this manual.

Locate the pump as close to the supply source as possible.

Install it in a lighted clean space where it will be easy to inspect and maintain.

## Motor and Controller

The P Series pump shaft can rotate in either direction, therefore direction of motor shaft rotation is not critical.

## Accessories

Consult installation drawing below for typical precision metering fluid system components. Contact Wanner Engineering or the distributor in your area for more details.

## Important Precautions

**Adequate Fluid Supply.** To avoid cavitation and premature pump failure, be sure that the pump will have an adequate fluid supply and that the inlet line will not be obstructed. See **Inlet Piping** on page 6.

**Positive Displacement.** This is a positive-displacement pump. To avoid severe system damage if the discharge line ever becomes blocked, install a relief valve downstream from the pump. See **Discharge Piping** on page 6.

**Safety Guards.** Follow all codes and regulations regarding installation and operation of the pumping system.

**Shut-Off Valves.** Never install shut-off valves between the pump and discharge pressure regulator, or in the regulator bypass line.

Consult the Factory for the following situations:

- Extreme temperature applications (above 160°F or below 40°F)
- Pressure feeding of pumps
- Viscous or abrasive fluid applications
- Chemical compatibility problems
- Hot ambient temperatures (above 110°F)

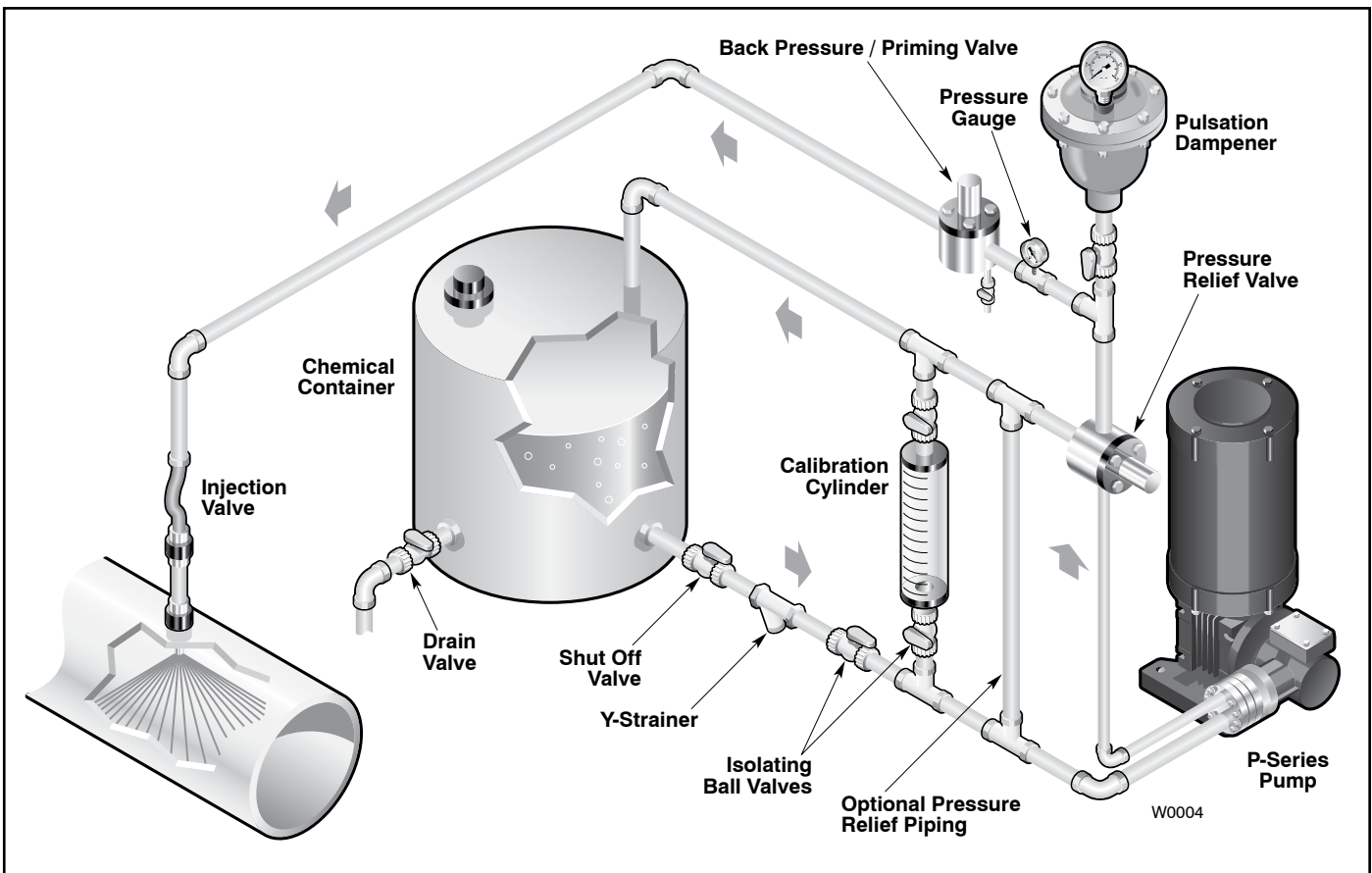

# P100 Installation

---

## Inlet Piping

Provide for permanent or temporary installation of a compound pressure gauge to monitor the inlet pressure. To maintain maximum flow, the pump inlet should be under flooded suction conditions at all times. **Do not supply more than one pump from the same inlet line.**

## Supply Tank

Use a supply tank that is large enough to provide time for any trapped air in the fluid to escape. The tank size should be at least twice the maximum pump flow rate.

Install a separate inlet line from the supply tank to each pump.

Place a cover over the supply tank, to prevent foreign objects from falling into it.

## Hose Sizing and Routing

To minimize acceleration head and frictional losses, size the suction line at least one size larger than the pump inlet, and keep the suction line as short and direct as possible.

Recommendations:

- Keep inlet lines less than 3 ft. (1 m) long
- Use at least 5/8" (16 mm) I.D. inlet hose
- Minimize fittings (elbows, valves, tees, etc.)

## Inlet Piping (Pressure Feed)

Provide for permanent or temporary installation of a pressure gauge to monitor the inlet pressure. Pressure at the pump inlet should not exceed 250 psi (17.3 bar). For higher pressures install a pressure reducing valve. **Do not supply more than one pump from the same inlet line.**

**Note: System back pressure must exceed the pump inlet pressure by at least 15 psi (1 bar) in order to prevent flow thru.**

## Discharge Piping

### Hose and Routing

Use the shortest, most-direct route for the discharge line.

Select pipe or hose with a **working pressure** rating of at least 1.5 times the maximum system pressure. EXAMPLE: Select a 1500 psi (103 bar) W.P. rated hose for a system to be operated at 1000 psi (69 bar) gauge pressure.

Support the pump and piping independently.

### Pressure Regulation

**Install a pressure relief valve in the discharge line.** Bypass pressure must not exceed the pressure limit of the pump.

Size the valve so that, when fully open, it will be large enough to relieve the full capacity of the pump without overpressurizing the system.

Locate the valve as close to the pump as possible and ahead of any other valves.

Adjust the pressure relief valve to no more than 10% over the maximum working pressure of the system. Do not exceed the manufacturer's pressure rating for the pump or valve.

Route the bypass line to the supply tank.

**CAUTION: Never install shutoff valves in the bypass line or between the pump and pressure regulator or relief valve.**

Provide for permanent or temporary installation of a pressure gauge to monitor the discharge pressure at the pump.

### Minimum Discharge Pressure

To ensure proper capacity control, a minimum discharge pressure of 50 psi (3.5 bar) is required.

# P100 Installation

## Initial Start-Up Procedure

Before you start the pump, be sure that:

- All shut-off valves are open, and the pump has an adequate supply of fluid.
  - All connections are tight.
  - The oil reservoir beneath the reservoir diaphragm (71) is completely full. NOTE: The reservoir is filled and sealed at the factory. If you are unsure about the oil level, remove the cover (70) and slowly lift the diaphragm (71). Refer to **6. Fill and Seal the Oil Reservoir** in the Fluid-End Service Section.
1. Open the priming valve on the system back pressure valve so the pump starts under minimum pressure.
  2. Turn on power to the pump motor.
  3. Check the inlet pressure or vacuum. To maintain maximum flow, the pump inlet should be under flooded suction conditions at all times. Inlet pressure must not exceed 250 psi (17.3 bar).
  4. Listen for any erratic noise and look for unsteady flow.
    - Jog the pump on and off until fluid coming from the priming valve is air-free.
    - Close the priming valve.

## Calibration Procedure

Each individual metering pump put into service must be calibrated in order to accurately determine required pump speed to achieve the desired flow. The capacity curves shown on page 3 represent a typical pump; individual pumps may vary slightly from these curves. In order to achieve the best possible results, perform calibration under actual process conditions. Follow these steps:

1. Run the pump for 20 minutes at actual process conditions. If the process system cannot be used, circulate back to the supply tank through a pressure relief valve (see Installation drawing on page 5). If required system pressure is less than 50 PSI (3.5 bar) a back pressure valve must be installed and set to produce a minimum of 50 PSI (3.5 bar) pressure at the pump head.
2. Determine maximum pump speed required for all system conditions that need to be satisfied. Measure pump delivery at this maximum speed using your system calibration cylinder, flow meter, or some other means. This is considered to be the “rated capacity” for your particular metering pump.
3. Measure pump delivery at 75%, 50%, 25%, and 10% of the maximum speed just determined. Let the pump run for 5 minutes at each speed setting before taking the capacity measurement.
4. Plot these values on linear graph paper using the horizontal axis for RPM and the vertical axis for GPH, or any other unit of measure you may be using for capacity.
5. Draw a best-fit straight line through the points just plotted. For stable conditions, this line predicts pump speed required to achieve desired flow over a 10:1 turndown ratio.

**Note: as pump discharge pressure increases, capacity decreases slightly (see Capacity curves on page 3). For any metering pump there are a series of valid capacity curves that may apply. Use the curve that depends on actual pump discharge pressure and other system conditions. It is critically important to develop a custom capacity curve for each pump and each system.**

## P100 Maintenance

**NOTE: The numbers in parentheses are Reference Numbers located in the Parts List exploded views of this manual.**

### Periodically

Change the oil according to the guidelines below. When changing, remove the drain plug (69). Allow all oil and contaminant to drain out. Catch the oil and dispose of it properly.

### Hours Between Oil Changes @ Various Process Fluid Temperatures

Pressure	<90°F (32°C)	<139°F (60°C)	<180°F (82°C)
<b>Metallic Pump Head</b>			
<1000 psi (70 bar)	6,000	4,000	2,000
<1500 psi (100 bar)	3,000	2,000	1,500
<b>Non-Metallic Pump Head</b>			
<250 psi (17 bar)	3,000	2,000	—

**NOTE: Minimum oil viscosity for proper hydraulic end**

**lubrication is 16-20 cST (80-100 SSU).**

**CAUTION: Do not turn the drive shaft while the oil reservoir is empty.**

There should be no trapped air under the oil reservoir diaphragm (71). Refer to **6. Fill and Seal the Oil Reservoir** in the Fluid-End Service Section.

Use the appropriate Hydra-Oil for the application.

**Note: P Series replacement parts kits (complete kits and diaphragm kits) include the appropriate oil for each specific P Series pump configuration.**

**CAUTION: If you are losing oil but don't see any external leakage, or if the oil becomes discolored and contaminated, the diaphragm (22) may be damaged. Refer to the Fluid-End Service Section. Do not operate the pump with a damaged diaphragm.**

**CAUTION: Do not leave contaminated oil in the pump housing or leave the housing empty. Remove contaminated oil as soon as discovered, and replace it with clean oil.**

Check the inlet pressure periodically with a gauge.

# P100 Fluid End Service

**NOTE:** The reference numbers in parentheses are shown in the Fluid End Parts List.

This section explains how to disassemble and inspect all easily-serviceable parts of the pump.

**CAUTION:** Do not disassemble the hydraulic end of the pump. For assistance, contact Wanner Engineering (612-332-5681) or the distributor in your area.

## 1. Remove Manifold (3)

- a. Remove all eight bolts (1) around manifold (3).
- b. Remove manifold (3).
- c. Inspect manifold for warping or wear around inlet and outlet ports. If wear is excessive, replace manifold or return it to Wanner Engineering for resurfacing.  
Place a straightedge across manifold to check if it is warped. If warped replace.

## 2. Inspect Valves (4-17)

The inlet and outlet valve assemblies are different (inlet valve is larger) and face opposite directions. Inspect each valve assembly as follows:

- a. Check spring retainers (4,17), and replace if worn.
- b. Check valve springs (5,16). If shorter than new spring, replace (do not stretch old spring).
- c. Check valve poppets (6,15). If worn excessively, replace.
- d. Remove valve seats (9,13) with seat puller. A seat puller is included in Wanner Tool Kit.  
Inspect valve seats for wear, and replace if necessary. New o-rings (8,12) should be installed.
- e. Check dampening washer (10), and replace if worn.
- f. Reinstall inlet and outlet valve assemblies:
  - Clean valve ports and shoulders with emery cloth, and lubricate with lubricating gel or petroleum jelly (do not use petroleum products when installing EPDM o-rings).
  - Install o-rings (8,12) on valve seats (9,13).
  - **Inlet Valve.** Insert spring retainer (17) into valve plate (21). Then insert spring (16), valve (15), Tetra seal (14) and valve seat (13). A flat Tetra seal o-ring (14) goes between spring retainer (17) and valve seat (13) when plastic retainer is used.
  - **Outlet Valve.** Insert dampening washer (10), valve seat (9), Tetra seal (7), valve (6), spring (5), and spring retainer (4). Install flat Tetra seal o-ring (14) between spring retainer (4) and valve seat (9) when plastic retainer is used.

## 3. Inspect and Replace Diaphragm (22)

- a. Use 3-mm Allen wrench to remove two capscrews (20) from valve plate (21).
- b. Lift diaphragm (22) by one edge, and turn pump shaft (**use the shaft rotator from the Wanner Tool Kit**) until diaphragm moves up to “top dead center”. This will expose machined cross holes in plunger shaft behind diaphragm.
- c. Insert plunger holder (from the Wanner Tool Kit) through one of machined cross holes to hold diaphragm up. The proper size tool is included in the Wanner Tool Kit. (Don't remove tool until new diaphragm is installed in step g below).
- d. Unscrew diaphragm (22). Use 8-mm or 5/16-in. open-end wrench and turn counterclockwise.
- e. Inspect diaphragm (22) carefully. A damaged diaphragm generally indicates a pumping system problem. Replacing diaphragm only, will not solve the larger problem. Inspect diaphragm for the following:
  - **Small puncture.** Usually caused by sharp foreign object in fluid.
  - **Diaphragm pulled away from sides.** Usually caused by fluid being frozen in pump, or by over-pressurization of pump.
  - **Diaphragm becoming stiff and losing flexibility.** Usually caused by pumping fluid that is incompatible with diaphragm material.
  - **Diaphragm edge chewed away.** Usually caused by over-pressurizing system.
- f. Clean away any spilled oil. Apply Loctite #242 Threadlocker to threads of new diaphragm (22) (or old one).
- g. Install diaphragm (22) and tighten to 10 in-lbs (113 N-cm).

**CAUTION:** If a diaphragm has ruptured and foreign material or water has entered the oil reservoir, do not operate the pump. Check the diaphragm, then flush the reservoir completely (as outlined below) and refill it with fresh oil. Never let the pump stand with foreign material or water in the reservoir, or with the reservoir empty.

# P100 Fluid End Service

---

## 4. Flush Contaminant from Hydraulic End

### (Only if diaphragm has ruptured)

- a. With valve plate and manifold still removed (see above), remove drain plug (69), cover (70), and diaphragm (71). Allow all oil and contaminant to drain out.
- b. Fill reservoir with kerosene or solvent. Manually turn pump shaft to circulate kerosene and drain. Dispose of contaminated fluid properly.  
**CAUTION: If you have an EPDM diaphragm, or if food grade oil is in the reservoir, do not use kerosene or solvents. Instead, flush with the same lubricant that is in the reservoir.**
- c. Repeat step b flushing procedure.
- d. Fill reservoir with fresh oil and manually turn pump shaft to circulate oil. Drain oil.
- e. Refill reservoir with fresh oil. If oil appears milky, there is still contaminant in reservoir. Repeat steps c and d until oil appears clean.

## 5. Prime Hydraulic Cell

- a. With pump **horizontal**, fill pump housing reservoir (62) with correct Hydra oil for application.  
**Note: P Series replacement parts kits (complete kits and diaphragm kits) include the correct oil for each specific P Series pump configuration.**
- b. All air in oil within hydraulic cell (behind diaphragm) must be forced out by turning shaft and pumping piston. A shaft rotator is included in the Wanner Tool Kit.  
Turn shaft until **bubble-free** flow of oil comes from behind diaphragm. Watch oil level in reservoir. If oil gets too low during priming air will be drawn into piston (inside hydraulic end). Air will cause pump to have loss in flow and repriming will be necessary. Fill oil reservoir completely. Add diaphragm seal and install cover plate.
- c. Wipe excess oil from reservoir cover (70) and reservoir diaphragm (71).

## 6. Fill and Seal Oil Reservoir

- a. Reservoir diaphragm (71) protrudes down into pump housing approximately 1/4 to 3/8 in. Add oil, if required, so that when diaphragm is set into reservoir all air is pushed out.  
Take care not to allow any oil overflow to get between pump housing (62) and cover (54). This may result in an apparent oil leak later, when the pump is put into use and heats up.
- b. Install reservoir cover (70) using four bolts (72).
- c. Wipe off excess oil on outside of pump housing.  
**NOTE:** The reservoir diaphragm (71) will flex up and down slightly as the pump operates. The vent holes in the reservoir cover (70) allow this to freely occur.

## 7. Reinstall Valve Plate (21) and Manifold (3)

- a. Reinstall valve plate (21), with valve assemblies installed as outlined above, onto diaphragm plate (24).
- b. Reinstall o-rings (18,19) onto valve plate (21). Use petroleum jelly or lubricating gel to hold them in place (do not use petroleum products when installing EPDM o-rings).
- c. Reinstall manifold (3) onto valve plate.
- d. Insert bolts (1) around edge of manifold, and alternately tighten opposite bolts until all are secure. Torque to 90 in-lbs (1017 N-cm).
- e. Recheck all bolts for tightness.

# P100 Fluid End Parts List

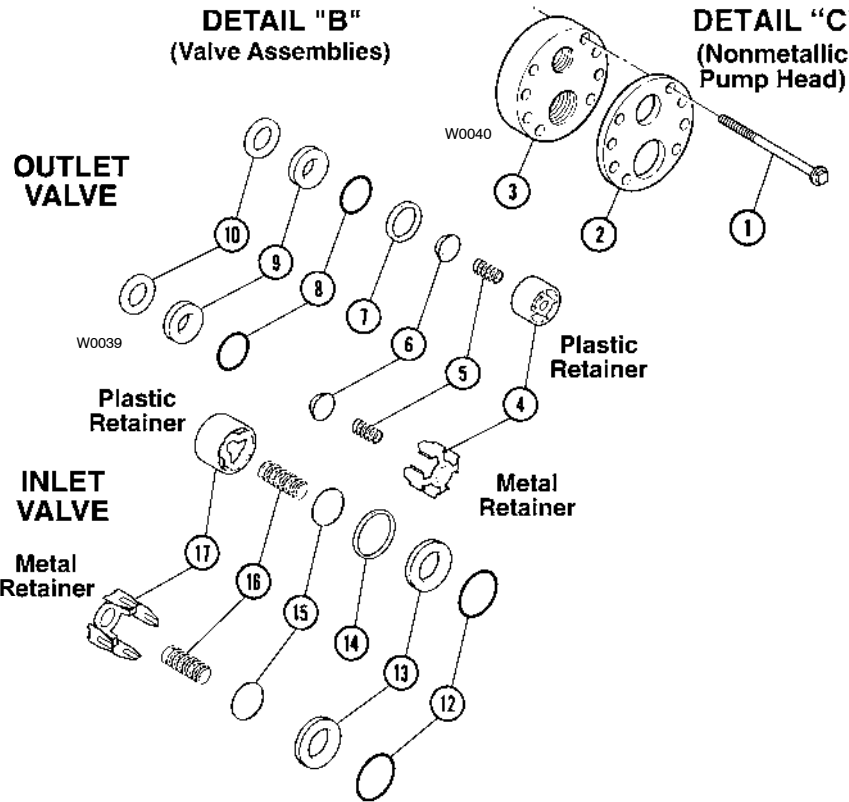
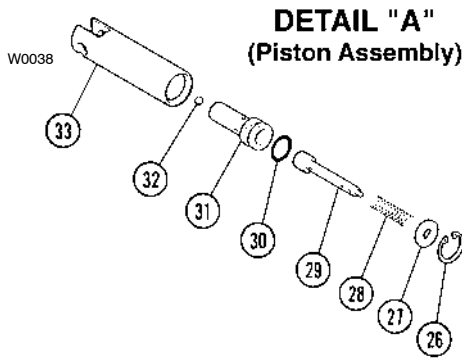
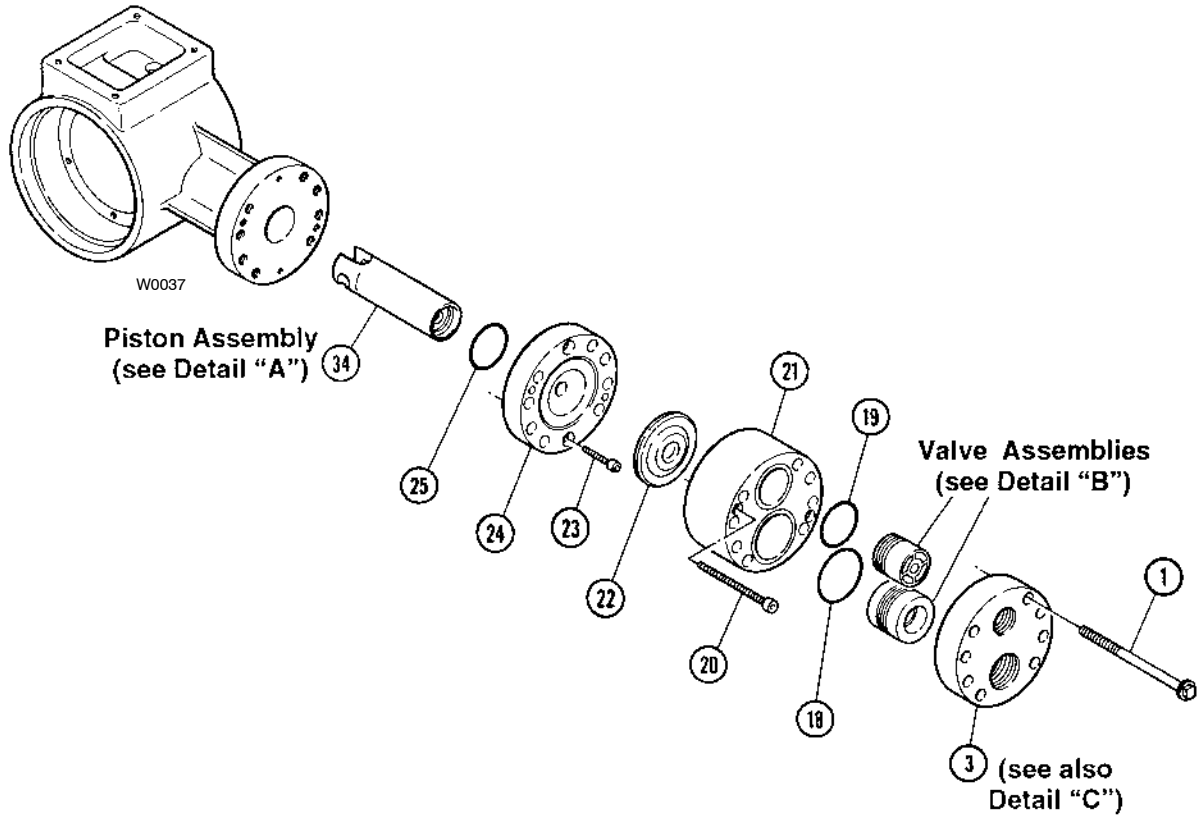

## Bolt Torque Specifications

Ref. No.	in-lbs	N-cm
1	90	1,017
20	14	158
22	10	113
23	14	158

# P100 Fluid End Parts List

Ref. No.	Part Number	Description	Quantity/ Pump	Ref. No.	Part Number	Description	Quantity/ Pump
1	G20-024-2010	Bolt, hex-head	8	15	D10-021-1011	Inlet Valve, Nitronic	1
2	F20-100-1010	Plate, manifold support (nonmetallic heads)	1		D10-021-1017	Inlet Valve, Hastelloy C	1
3	F20-004-1012	Manifold, 316 SST, NPT	1		D10-021-3300	Inlet Valve, ceramic	1
	F20-004-1017	Manifold, Hastelloy C, NPT	1	16	D10-022-3117	Valve Spring, inlet, Elgiloy	1
	F20-004-1050	Manifold, polypropylene, NPT	1		D10-022-3123	Valve Spring, inlet, Hastelloy C	1
	F20-004-1053	Manifold, Kynar, NPT	1	17	D10-023-1017	Retainer, inlet valve spring, Hastelloy C	1
	G20-004-1012	Manifold, 316 SST, BSPT	1		D10-023-2327	Retainer, inlet valve spring, polypropylene	1
	G20-004-1017	Manifold, Hastelloy C, BSPT	1		D10-023-2328	Retainer, inlet valve spring, Kynar	1
	G20-004-1050	Manifold, polypropylene, BSPT	1	18	F20-074-2110	O-ring, inlet manifold, Buna	1
	G20-004-1053	Manifold, Kynar, BSPT	1		F20-074-2111	O-ring, inlet manifold, Viton	1
4	D03-023-1017	Retainer, outlet valve spring, Hastelloy C	1		F20-074-2112	O-ring, inlet manifold, neoprene	1
	D03-023-2317	Retainer, outlet valve spring, polypropylene	1		F20-074-2113	O-ring, inlet manifold, EPDM	1
	D03-023-2318	Retainer, outlet valve spring, Kynar	1		F20-074-2118	O-ring, inlet manifold, PTFE	1
5	D03-022-3113	Valve Spring, outlet, Hastelloy C	1	19	F20-073-2110	O-ring, outlet manifold, Buna	1
	D03-022-3114	Valve Spring, outlet, Elgiloy	1		F20-073-2111	O-ring, outlet manifold, Viton	1
6	D03-021-1011	Outlet Valve, Nitronic	1		F20-073-2112	O-ring, outlet manifold, neoprene	1
	D03-021-1017	Outlet Valve, Hastelloy C	1		F20-073-2113	O-ring, outlet manifold, EPDM	1
	D03-021-3300	Outlet Valve, ceramic	1		F20-073-2118	O-ring, outlet manifold, PTFE	1
7	D03-092-2110	Tetra Seal, outlet, Buna	1	20	G20-029-2010	Cap Screw, socket-head	2
	D03-092-2111	Tetra Seal, outlet, Viton	1	21	F20-003-1012	Valve Plate, 316 SST	1
	D03-092-2112	Tetra Seal, outlet, neoprene	1		F20-003-1017	Valve Plate, Hastelloy C	1
	D03-092-2113	Tetra Seal, outlet, EPDM	1		F20-003-1050	Valve Plate, polypropylene	1
	D03-035-2118	Tetra Seal, outlet, PTFE	1		F20-003-1053	Valve Plate, Kynar	1
8	D03-035-2112	O-ring, outlet valve seat, neoprene	1	22	D03-018-1212	Diaphragm, neoprene	1
	D03-035-2113	O-ring, outlet valve seat, EPDM	1		D03-018-1213	Diaphragm, EPDM	1
	D03-035-2118	O-ring, outlet valve seat, PTFE	1		D03-018-1215	Diaphragm, Viton-XT	1
	D25-046-2110	O-ring, outlet valve seat, Buna	1		D03-018-1218	Diaphragm, PTFE	1
	D25-046-2111	O-ring, outlet valve seat, Viton	1		D03-018-1220	Diaphragm, Buna-N-XS	1
9	D03-020-1001	Valve Seat, outlet, 316 SST	1	23	G20-088-2010	Cap-Screw, socket-head	2
	D03-020-1017	Valve Seat, outlet, Hastelloy C	1	24	F20-002-1010	Diaphragm Plate	1
	D03-020-3300	Valve Seat, outlet, ceramic	1	25	D03-075-2110	O-ring, diaphragm plate, Buna	1
10	D03-125-2317	Washer, outlet dampening, polypropylene	1	26	D03-048-2210	Snap Ring	1
	D03-125-2318	Washer, outlet dampening, Kynar	1	27	D03-049-1000	Washer	1
12	D10-035-2110	O-ring, inlet valve seat, Buna	1	28	D03-045-3110	Spring, sleeve valve	1
	D10-035-2111	O-ring, inlet valve seat, Viton	1		D03-045-3111	Spring, sleeve valve for PTFE diaphragm	1
	D10-035-2112	O-ring, inlet valve seat, neoprene	1	29	D03-044-1000	Valve Plunger	1
	D10-035-2113	O-ring, inlet valve seat, EPDM	1	30	D03-034-2110	O-ring, valve cylinder, Buna	1
	D10-035-2118	O-ring, inlet valve seat, PTFE	1	31	D03-043-1000	Valve Cylinder	1
13	D10-020-1011	Valve Seat, inlet, 316 SST	1	32	D10-015-3010	Ball	1
	D10-020-1017	Valve Seat, inlet, Hastelloy C	1	33	D03-014-1004	Piston	1
	D10-020-3300	Valve Seat, inlet, ceramic	1	34	D03-014-1210	Piston Assembly	1
14	D10-092-2110	Tetra Seal, inlet, Buna	1				
	D10-092-2111	Tetra Seal, inlet, Viton	1				
	D10-092-2112	Tetra Seal, inlet, neoprene	1				
	D10-092-2113	Tetra Seal, inlet, EPDM	1				
	D10-092-2118	Tetra Seal, inlet, PTFE	1				

# P100 Hydraulic End Parts Lists

Ref. No.	Part Number	Description	Quantity/ Pump
52	G20-086-2010	Screw, cap, hex-flange-head .....	6
53	F20-036-2110	O-ring, back cover screws, Buna.....	6
54	G20-131-1010	Cover.....	1
55	F20-037-2110	O-ring, cover, Buna .....	1
56	F20-031-2110	Seal, Buna.....	1
57	D03-010-2910	Back Bearing.....	1
58	F20-009-1003	(X) Hollow Shaft, 5/8" ID.....	1
59	D03-132-1000	Connecting Rod .....	1
60	F20-010-2910	Front Bearing .....	1
61	D03-133-1000	Pin .....	1
62	G20-001-1033	Pump Housing .....	1
65	D10-085-2210	Key, shaft .....	1
69	D10-038-2210	Plug, drain .....	1
70	F20-105-1020	Cover, oil reservoir .....	1
71	F20-091-1010	Diaphragm, oil reservoir.....	1
72	G20-090-2010	Screw, cap, hex-head.....	4

## Hydraulic End Service

**CAUTION:** Do not disassemble or service the hydraulic end.

For assistance, contact Wanner Engineering at (612)332-5681 for the distributor in your area.

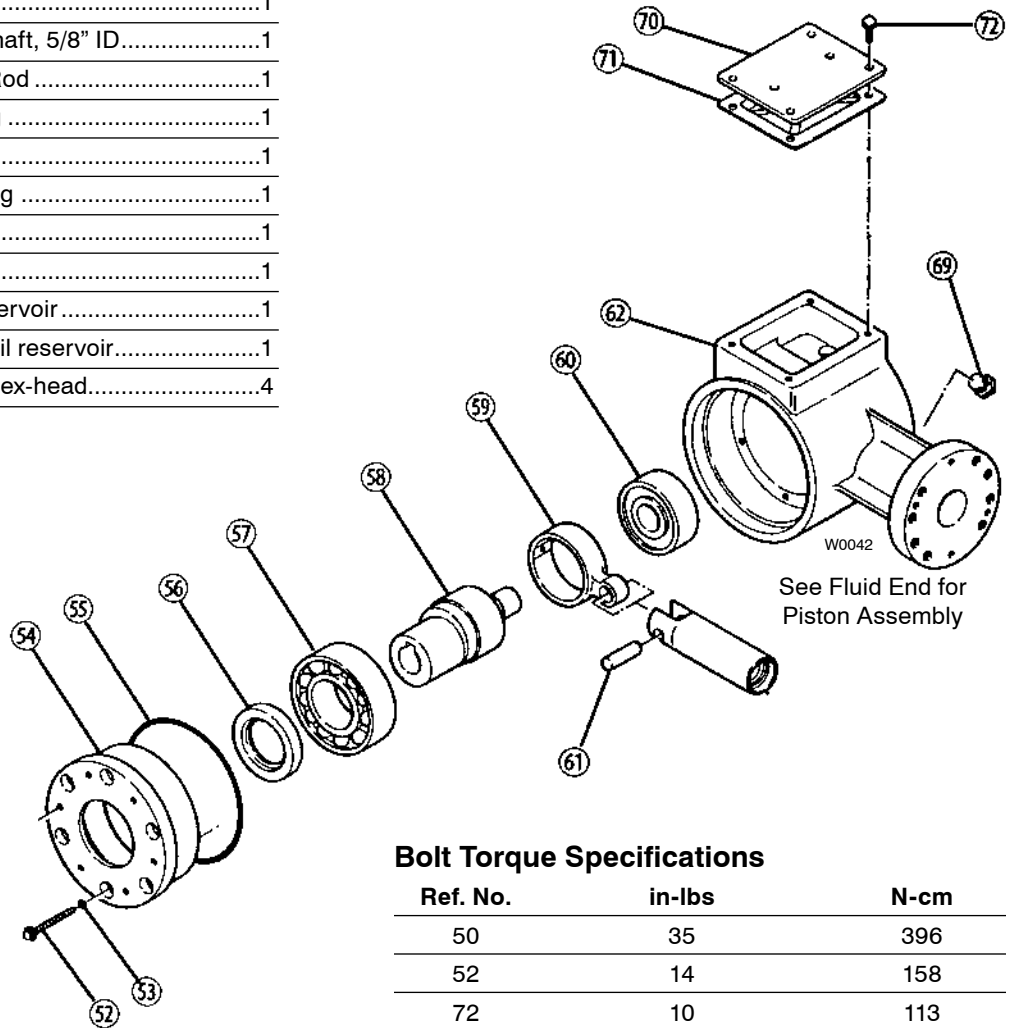

### Bolt Torque Specifications

Ref. No.	in-lbs	N-cm
50	35	396
52	14	158
72	10	113
75	35	396

# P100 Reducer/Base Assembly

Ref. No.	Part Number	Description	Quantity/ Pump
100	112-100	Reducer, 5:1 ratio, 56C .....	1
	112-101	Reducer, 7.5:1 ratio, 56C .....	1
	112-102	Reducer, 10:1 ratio, 56C .....	1
	112-103	Reducer, 15:1 ratio, 56C .....	1
	112-104	Reducer, 20:1 ratio, 56C .....	1
	112-105	Reducer, 25:1 ratio, 56C .....	1
	112-106	Reducer, 30:1 ratio, 56C .....	1
	112-107	Reducer, 40:1 ratio, 56C .....	1
	112-108	Reducer, 50:1 ratio, 56C .....	1
	112-109	Reducer, 60:1 ratio, 56C .....	1
	112-110	Reducer, 80:1 ratio, 56C .....	1
	112-111	Reducer, 100:1 ratio, 56C .....	1
101	112-112	Kit, Protective Cover .....	1
102	112-116	Kit, Output Flange, FD .....	1
103	112-115	Kit, Single Output Shaft, 5/8" dia.....	1
104	F20-120-1020	Adapter, P100.....	1
105	G20-089-2020	Screw, FHS, M5 x 0.8 x 19 mm.....	6
106	100-914	Screw, HHCS, 5/16-18 UNC x 3/4" .....	3
107	100-915	Washer, flat, 5/16" .....	3
108	112-124	Metering Pump Base, Aluminum, painted (and attaching hardware) .....	1

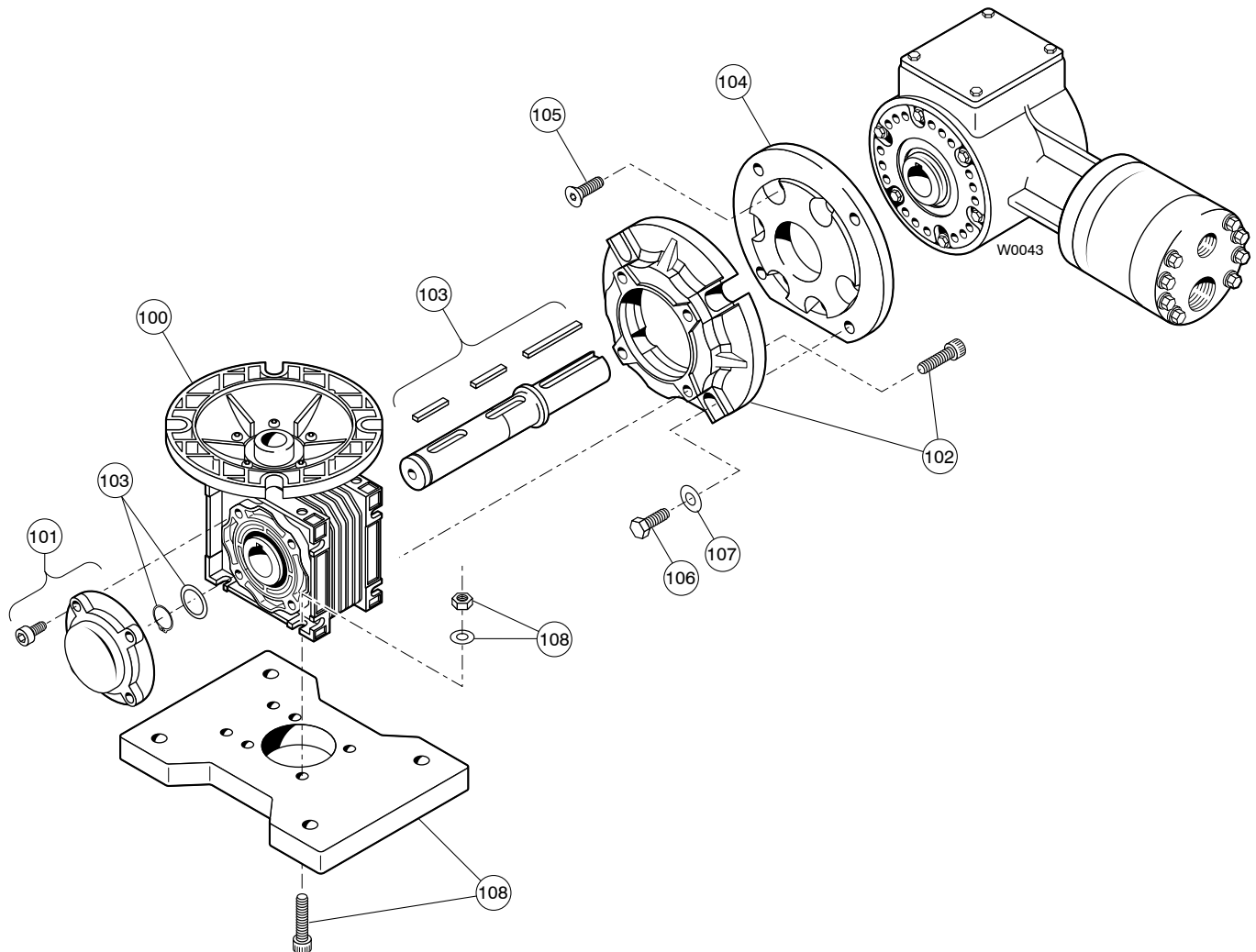

# P100 Troubleshooting

Problem	Probable Cause	Solution
<b>Motor/Pump Does Not Operate:</b>	No power.	Supply correct power according to motor requirements.
	Blown fuse/tripped circuit breaker.	Replace/reset, eliminate circuit overload.
	Shaft coupling to pump not in place.	Install proper coupling hardware (see parts list).
	Current overload - motor.	Motor not rated for pump operating conditions - install proper motor.
	Thermal overload - motor.	Motor not rated for pump and/or ambient operating conditions - supply cooling or install proper motor.
	Faulty motor drive/controller.	Repair/replace.
	Faulty motor.	Repair/replace.
	Low liquid level in supply tank (if low-level shut-off is used).	Fill tank.
<b>No Delivery</b>	Supply tank empty.	Fill tank.
	Inlet line or strainer clogged.	Clear debris and flush, or replace.
	Inadequate supply pressure at pump inlet.	Increase supply pressure by raising fluid level in tank, raising tank, or pressurizing suction tank.
	Inlet line too restrictive.	Increase inlet line diameter and/or decrease inlet line length.
	Fluid viscosity too high.	Reduce viscosity if possible (by heat or some other means). Increase inlet line diameter and/or decrease inlet line length. Increase supply pressure.
	Vapor lock/cavitation.	Increase inlet pressure. Decrease fluid temperature.
	Pump valves held open or worn out.	Clear debris and flush, or replace (see Fluid End Service)
	System relief valve actuating.	Adjust relief valve, or repair, clean, or replace with new relief valve.
<b>Delivery Too Low and/or Erratic</b>	Review all Probable Causes and Solutions in Problem 2 No Delivery above.	
	Air leak(s) in inlet line.	Locate all leaks and repair.
	System back pressure too low.	Adjust back pressure valve to higher setting. Install back pressure valve if none in system.
	Pumped fluid characteristics changed.	Monitor supply tank temperature to determine if fluid is too hot (leading to cavitation) or too cold (increasing fluid viscosity). Stabilize temperature at suitable level to resolve problem. Check for entrapped air in the fluid supply system.
	Inlet supply pressure changed.	Monitor inlet supply pressure (at the pump) to determine if it is too low, causing a starved condition/cavitation. Stabilize pressure at suitable level to resolve problem.
	Pump OK - Calibration system or flow meter error.	Evaluate components and repair/correct problem(s).
	Oil condition in pump hydraulic end changed.	Check oil level - if low evaluate for source of leakage. Consult factory for hydraulic end service.
		Change oil per recommended guidelines in maintenance section.
<b>Delivery Too High and/or Erratic.</b>	System back pressure too low.	Adjust back pressure valve to higher setting. Install back pressure valve if none in system.
	Inlet supply pressure changed.	Monitor inlet supply pressure (at the pump) to determine if it is too high, causing a "flow-through" condition. Stabilize pressure at suitable level to resolve problem.
	Pump OK - Calibration system or flow meter error.	Evaluate components and repair/correct problem(s).

# P100 Replacement Parts Kits

TO ORDER REPLACEMENT PARTS KIT: A Replacement Parts Kit contains 9 digits corresponding to customer-specified design options.

1	2	3	4	5	6	7	8	9
---	---	---	---	---	---	---	---	---

Digit	Order Code	Description
<b>1-2</b>		<b>Pump Configuration</b>
	P1	For all P100 Pumps
<b>3</b>		<b>Kit Designator</b>
	K	Complete Fluid End Kit*
	D	Diaphragm Kit*
	V	Valve Kit
<b>4-5</b>		<b>Pump Head Version</b>
	52	Standard
<b>6</b>		<b>Spring Retainers/Dampening Washers</b>
	M	For Kynar® pump head
	P	For Polypropylene pump head
	S	For 316 Stainless Steel pump head
	T	For Hastelloy® C pump head
	X	Not included in Diaphragm Kit
<b>7</b>		<b>Diaphragm &amp; O-ring Material</b>
	E	EPDM
	G	Viton®-XT
	J	PTFE
	P	Neoprene
	T	Buna-N-XS
<b>8-9</b>		<b>Check Valve Material (Valve Spring / Valve &amp; Seat)</b>
	SS	316 SST / 316 SST
	TT	Hastelloy® C / Hastelloy® C
	SC	316 SST / Ceramic
	TC	Hastelloy® C / Ceramic
	XX	Not included in Diaphragm Kit

\* Includes Hydraulic End Oil

## Kit Contents

Part Number*	Description	Qty	Kit Designator		
			K	D	V
D03-018-___	Diaphragm	1	•	•	
F20-073-___	O-ring, outlet manifold	1	•	•	•
F20-074-___	O-ring, inlet manifold	1	•	•	•
D03-035-___	O-ring, outlet valve seat	1	•		•
D03-020-___	Valve seat, outlet	1	•		•
D03-021-___	Valve, outlet	1	•		•
D03-022-___	Valve spring, outlet	1	•		•
**D03-092-___	Tetra seal, outlet	1	•		•
D03-023-___	Retainer, outlet valve spring	1	•		•
D03-125-___	Washer, outlet dampening	1	•		•
D11-035-___	O-ring, inlet valve seat	1	•		•
D10-020-___	Valve seat, inlet	1	•		•
D10-021-___	Valve, inlet	1	•		•
D10-022-___	Valve spring, inlet	1	•		•
**D10-092-___	Tetra seal, inlet	1	•		•
D10-023-___	Retainer, inlet valve spring	1	•		•
A01-113-3400	Threadlocker	1	•		•
	Hydraulic End Oil	(0.5 qt)	•		•

\* Last four digits of part numbers with -\_\_\_ refer to specific material of construction.

\*\* Not included with metal spring retainers.

### **Limited Warranty**

Wanner Engineering, Inc. extends to the original purchaser of equipment manufactured by it and bearing its name, a limited one-year warranty from the date of purchase against defects in material or workmanship, provided that the equipment is installed and operated in accordance with the recommendations and instructions of Wanner Engineering, Inc. Wanner Engineering, Inc. will repair or replace, at its option, defective parts without charge if such parts are returned with transportation charges prepaid to Wanner Engineering, Inc., 1204 Chestnut Avenue, Minneapolis, Minnesota 55403.

This warranty does not cover:

1. The electric motors (if any), which are covered by the separate warranties of the manufacturers of these components.
2. Normal wear and/or damage caused by or related to abrasion, corrosion, abuse, negligence, accident, faulty installation or tampering in a manner which impairs normal operation.
3. Transportation costs.

This limited warranty is exclusive, and is in lieu of any other warranties (express or implied) including warranty of merchantability or warranty of fitness for a particular purpose and of any non-contractual liabilities including product liabilities based on negligence or strict liability. Every form of liability for direct, special, incidental or consequential damages or loss is expressly excluded and denied.

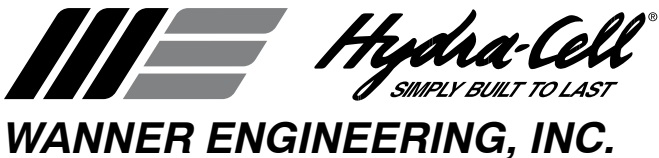

1204 Chestnut Avenue, Minneapolis, MN 55403  
TEL: (612) 332-5681 FAX: (612) 332-6937  
TOLL-FREE FAX [US only]: (800) 332-6812

[www.epmpump.com](http://www.epmpump.com)  
email: [sales@wannereng.com](mailto:sales@wannereng.com)

© 2005 Wanner Engineering, Inc. Printed in USA  
P100-991-2400A 8/2005, Revised 1/2006