

Electronically commutated spherical motor, 12 VDC, Centrifugal Pumps



- ECM - Electronically Commutated Motor
- Ultra Efficient
- Low Power Consumption
- Long Life
- Continuous Duty
- Variable Speed
- Small Footprint
- Very Quiet

Designed for OEM applications such as Thermal Management, Laser Cooling and Medical Equipment

The Laing DDC pump is an ideal 12 VDC solution for liquid cooling of medical equipment, lasers and personal body cooling. Due to its size and output, the Laing DDC can also be used in a large number of other applications.

The Laing DDC is an electronically commutated spherical motor pump, with an expected service life up to 50,000 hours .

The only moving part in a spherical motor pump is a spherically shaped rotor/impeller unit, which is seated on an ultra-hard, wear-resistant ceramic ball. The conventional shaft, shaft bearings and shaft seals have been eliminated, which reduces noise and extends the life of the pump.

The spherical motor design permits economical operation with comparatively high output. Supply voltage variation provides a simple means of controlling the speed of the DDC pump over a large output range. All parts in contact with the medium are 100% corrosion resistant. An optional tachometer output provides feedback to monitor the speed of the pump directly.



Threaded DDC Pump



Standard DDC Pump



Footed DDC Pump



Center Suction
DDC Pump



Model Code



Laing Thermotech
a xylem brand



DDC Series
DDC 3.1: max. 12 Watt
DDC 3.15: max. 12 Watt
DDC 3.2: max. 18 Watt
DDC 3.25: max. 20 Watt

T: Tach Output
Blank: No Tach Output

P: Plug
Black: No Plug

MP: Mounting Feet Parallel
MC: Mounting Feet Cross
Blank: No Mounting Feet

T: 1/4"PT
Blank: 3/8" Hosebarb
CS: Center suction

Dimensions

1/4" R Male Connection

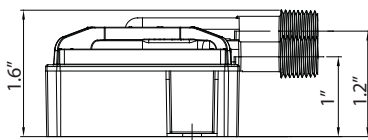

3/8" Hosebarb Connection

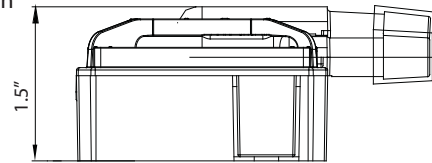
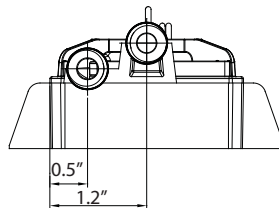

CS: Center suction

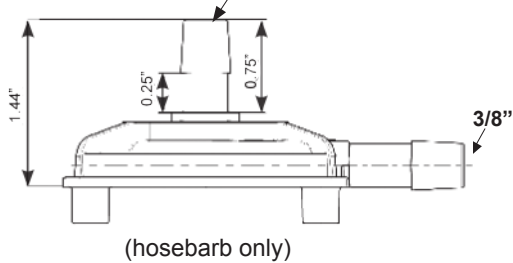

(hosebarb only)

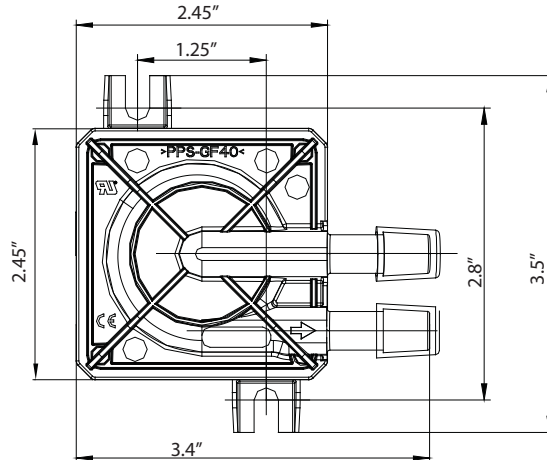

Family Curve

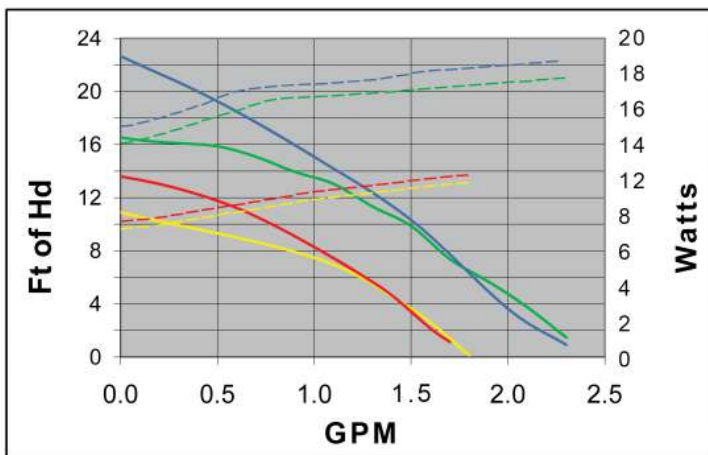

Note: The dashed lines represent power curves

— DDC - 3.1 — DDC - 3.2
— DDC - 3.15 — DDC - 3.25

Technical Data

Motor design: Electronically commutated spherical motor
 Rated voltage: 12 Volt DC
 Power consumption: DDC 3.1: max. 12 Watt, DDC 3.15: max. 12 Watt
 DDC 3.2: max. 18 Watt, DDC 3.25: max. 20 Watt
 Voltage range: 8 to 13.2 Volts*
 Acceptable media: Water, Water/Glycol Mixtures**
 Other media on request
 Max. system pressure: 21.75 PSI
 Max. system temperature: 140° F
 Wetted parts: Rotor/impeller material: stainless steel grade 316Ti, PPS-GF40 is the pump housing material and the impeller, EPDM O-ring, aluminum oxide ceramic ball, carbon bearing cap

Electrical wire connection: PA6.6 GF35

*Minimum startup Voltage 9 Volt

** Check pump performance for mixtures of 20% or more glycol. Please contact us regarding any other media requirements.



IALT-00290.D May 2016

www.IwakiCustomPumps.com

