

Gardner
Denver

POSITIVE DISPLACEMENT

Industrial Blowers





It's all about...

the NETWORK





We're Where You Need Us

It's all about...

the RANGE

Gardner Denver provides more technology styles than anyone else.
This means **YOU** can tailor technologies to **YOUR** needs.

Bi-Lobe



Tri-Lobe



Twisted Tri-Lobe



Screw

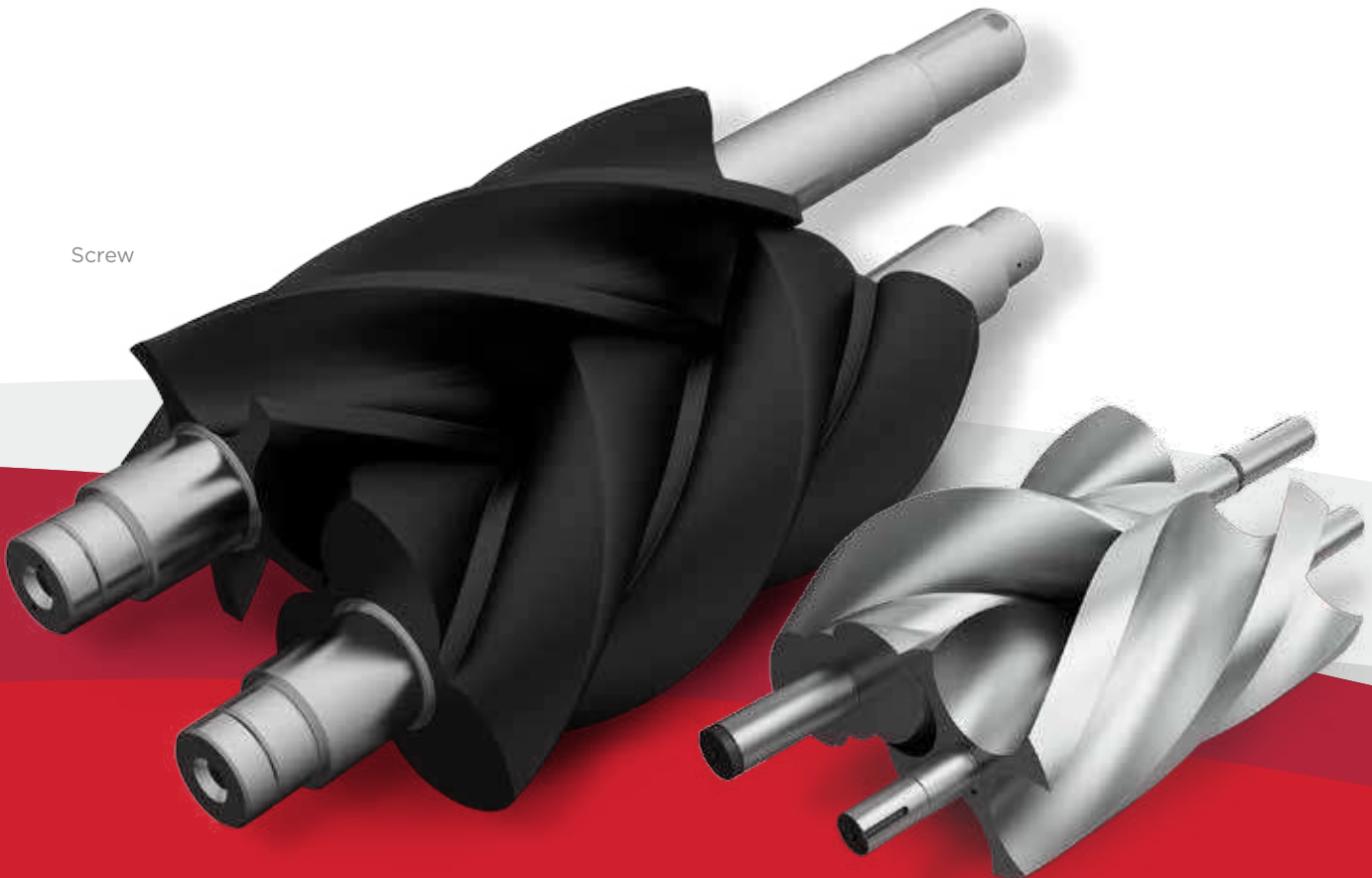

CycloBlower
Airend Bi-Lobe
Efficiency Mix
Opportunity Blend
Option Choice Reliability Helical Selection
Tri-Lobe Expansive Tri-Lobe DuroFlow
Tri-Lobe Range
Sutorbilt Quiet Durable
Side Channel Package HeliFlow Blend Bi-Lobe Screw
Technology Benefit
Design Longevity
Conclusion World-Class
Solution

It's all about...

your NEEDS

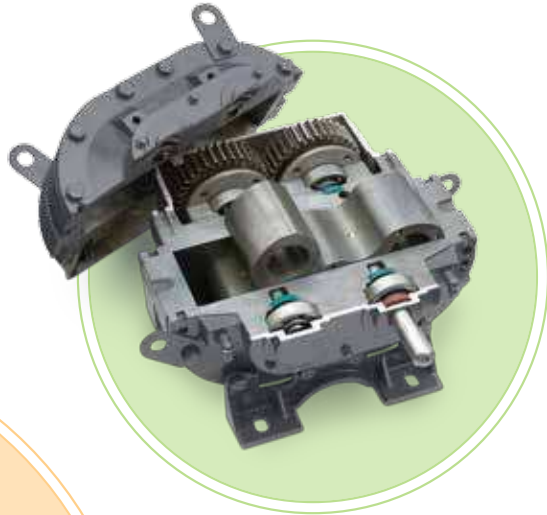

Cost

BI-LOBE

Selection
Tools

QUICKPIK

YO
NEE



IQ BLOWER
PACKAGE

Package
Options



OUR EDS

Energy
Savings

HELICAL
SCREW

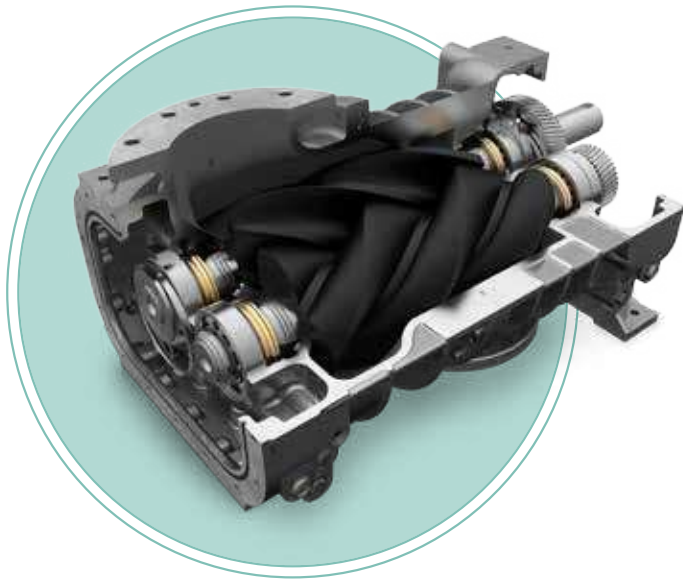

Noise
Reduction

HELICAL SCREW
& TRI-LOBE

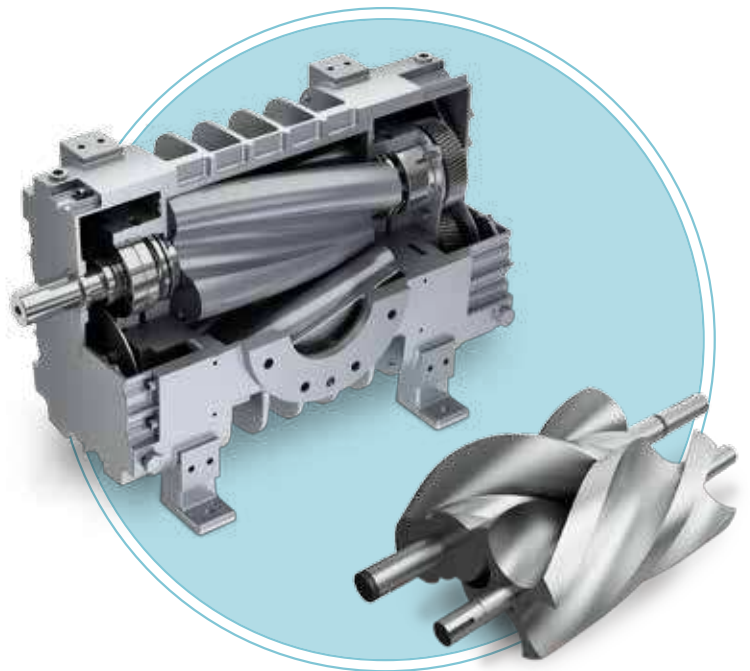

Tough
Environments

SOLID
BI-LOBE



It's all about...

the SIZING

QuickPik helps you customize our products to meet your demands.

Try it now!

Scan the QR code or visit:

www.GDQuickPik.com

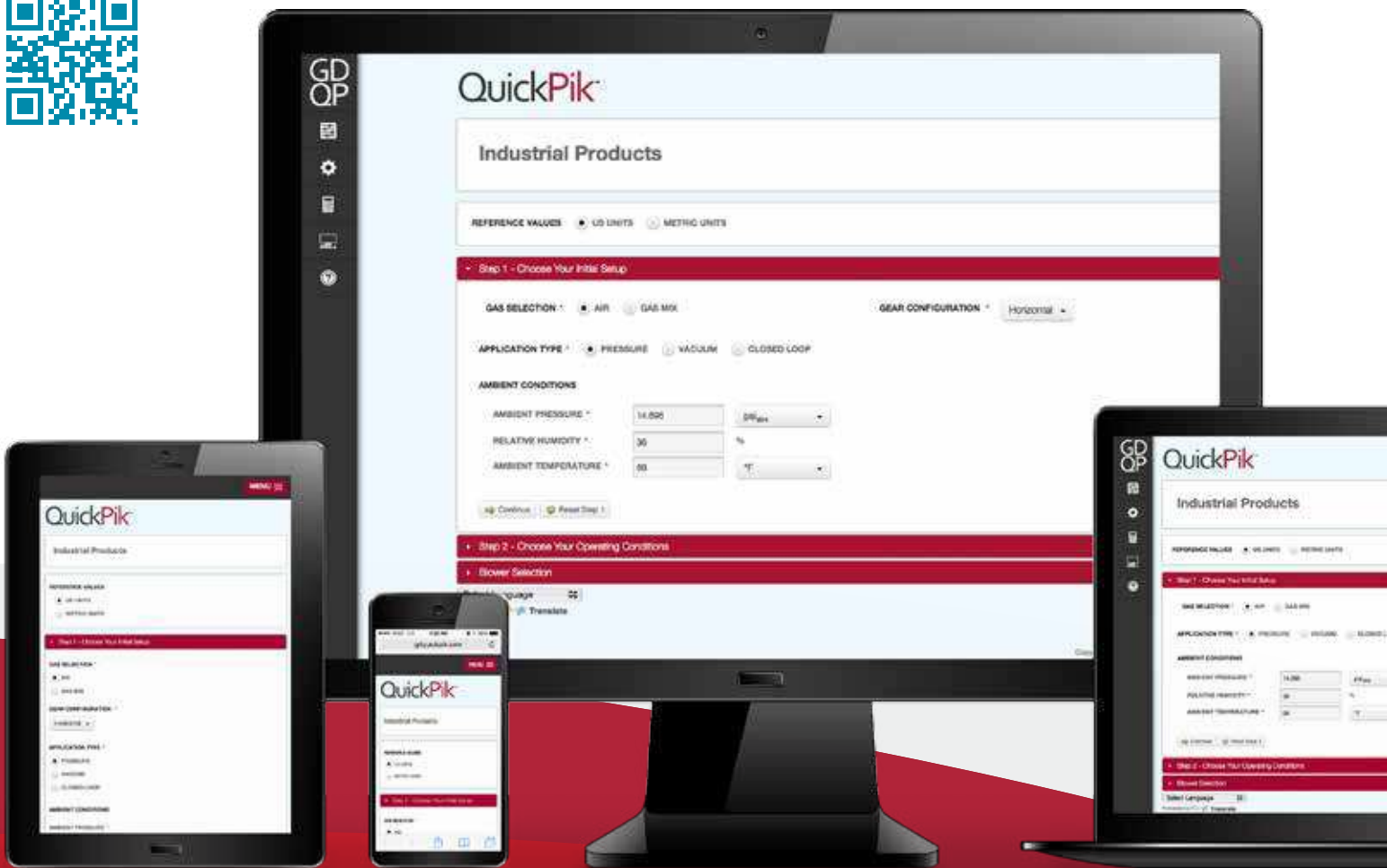

CycloBlower - 5CDL9

Download Performance Curves Find a Distributor

Product Information

ORIGINAL UNITS

CONFIGURATIONS	FLOW ICFM	SPEED RPM	RPM % OF MAX	POWER HP	TEMP ° F	NOISE DBA	TEMP % OF MAX
Original	500	3536	71	30.8	154	87	55
Current	500	3536	71	30.8	154	87	55

ENGLISH UNITS

CONFIGURATIONS	FLOW ICFM	SPEED RPM	RPM % OF MAX	POWER HP	TEMP ° F	NOISE DBA	TEMP % OF MAX
Original	500	3536	71	30.8	154	87	55
Current	500	3536	71	30.8	154	87	55

METRIC UNITS

CONFIGURATIONS	FLOW M ³ /H	SPEED RPM	RPM % OF MAX	POWER KW	TEMP ° C	NOISE DBA	TEMP % OF MAX
Original	350	3536	71	22.4	90	87	55
Current	350	3536	71	22.4	90	87	55

Performance Curves



Comparison



PRODUCT	CycloBlower 5CDL9	SubMini Liquid 20	SubMini A2
FLOW/CFM	500	500	500
SPEED/RPM	3536	3536	3541
RPM % OF MAX	71	62	56
POWER/HP	32	31	32
OPERATING TEMP °F	154	201	214
NOISE/DBA	87	82	82
OPERATING TEMP % OF MAX	55	69	61
PERFORMING TEMP MAX	52	72	72

Sizing Made Simple

- Accessible information at your fingertips
- Compare & contrast blowers
- Fit technology to your exact needs
- Mobile-friendly design for your laptop, tablet & phone
- Will work off-line
- Set up and customize your profile
- Save selections for future reference

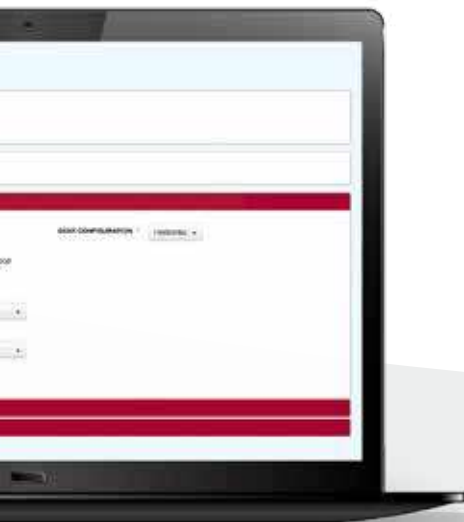

It's all about...

the SUTORBILT



Legend DSL 5M

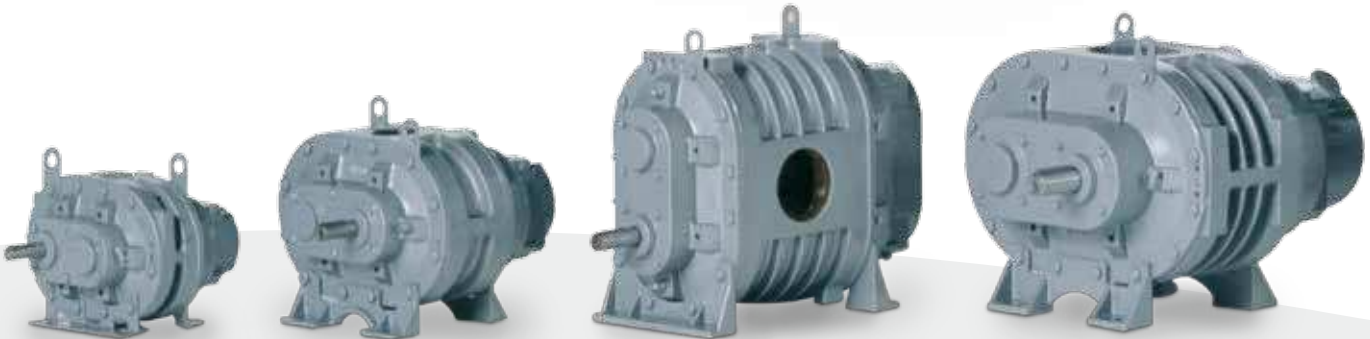



2MP LHC

3MR RHC

4LVR BHC

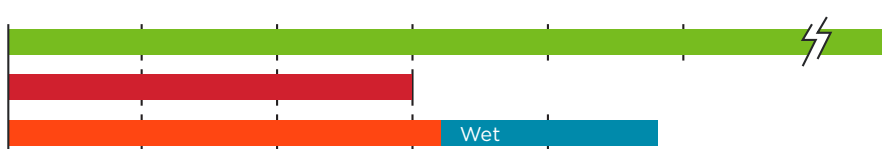
5MR RHC

Technology	Specifications			
Bi-Lobe	UP TO 26,000 CFM 15 PSI 24 inHg		Wet	

The most versatile blower available!

Over 240 configuration options!

Gear Sizes	Legend 2-8"	DSL Legend 3-6"	4500 6-8"	8000 10-22"
Lubrication Options	Grease	Dual Splash	Dual Splash	Dual Splash Force Feed
Seal Options	Lip Mechanical	Lip Mechanical	Lip Mechanical	Lip Mechanical
Coating Options	Corrgard	Corrgard	Corrgard	Corrgard Nickel
Quiet Series Option	Yes	Yes	No	Yes
Wet Vacuum	No	No	No	Yes



DSL



4500



8000

It's all about...

the DUROFLOW

Dual Splash Lubrication
for Longer Product Life (5)

Shaft Splines Assure
Non-Slip Rotor Timing (6)

Advanced
Oil & Air Seals Provide
Leak-Free Operation

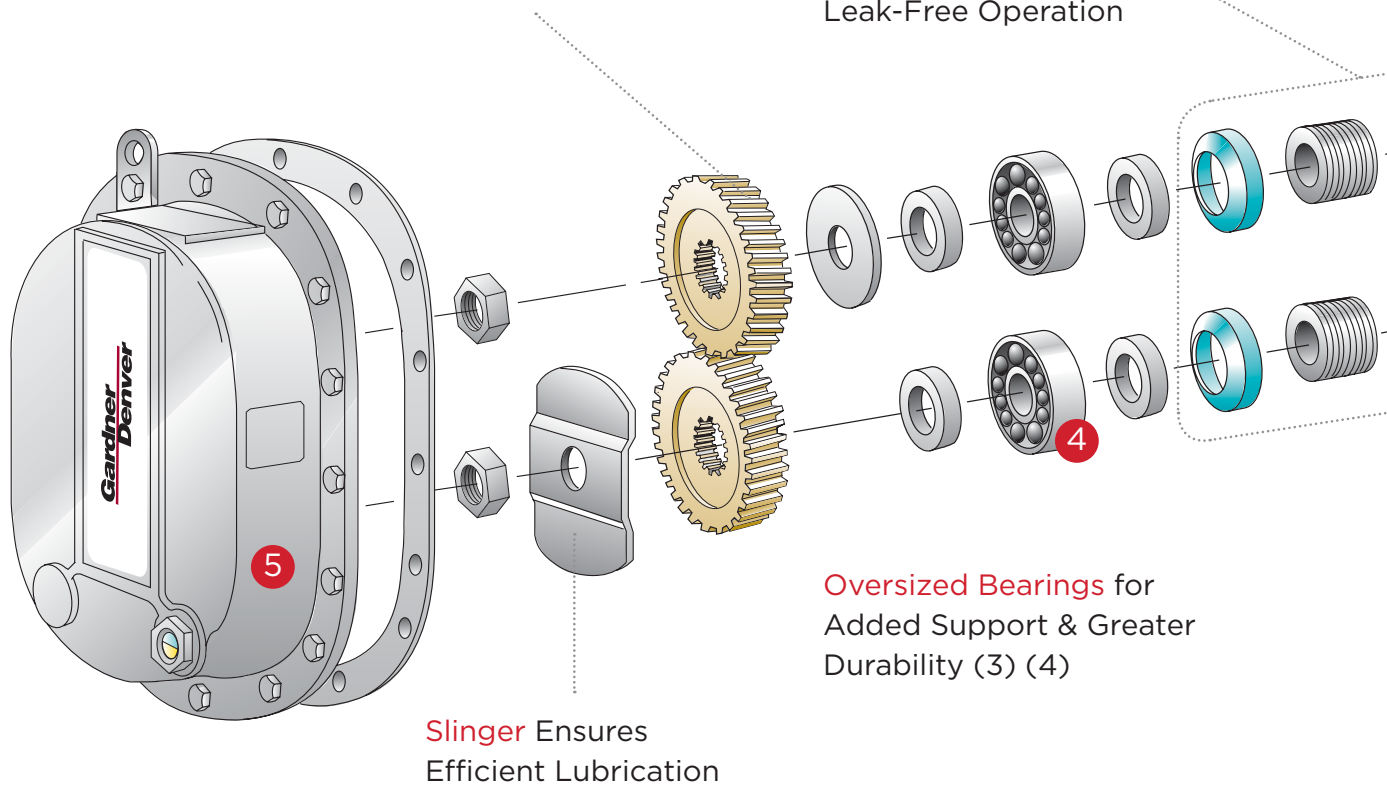

Oversized Bearings for
Added Support & Greater
Durability (3) (4)

Slinger Ensures
Efficient Lubrication

Technology	Specifications		
Bi-Lobe	UP TO		
	4,300	CFM	
	15	PSI	
	16	inHg	

High-Strength, Ductile Iron Cast **Solid Rotors** Eliminate Potential for Vibration

Single Piece Cylinder Prevents Distortion (1)

Integral Ribs for Cooler Operating Temperatures & Improved Performance (2)

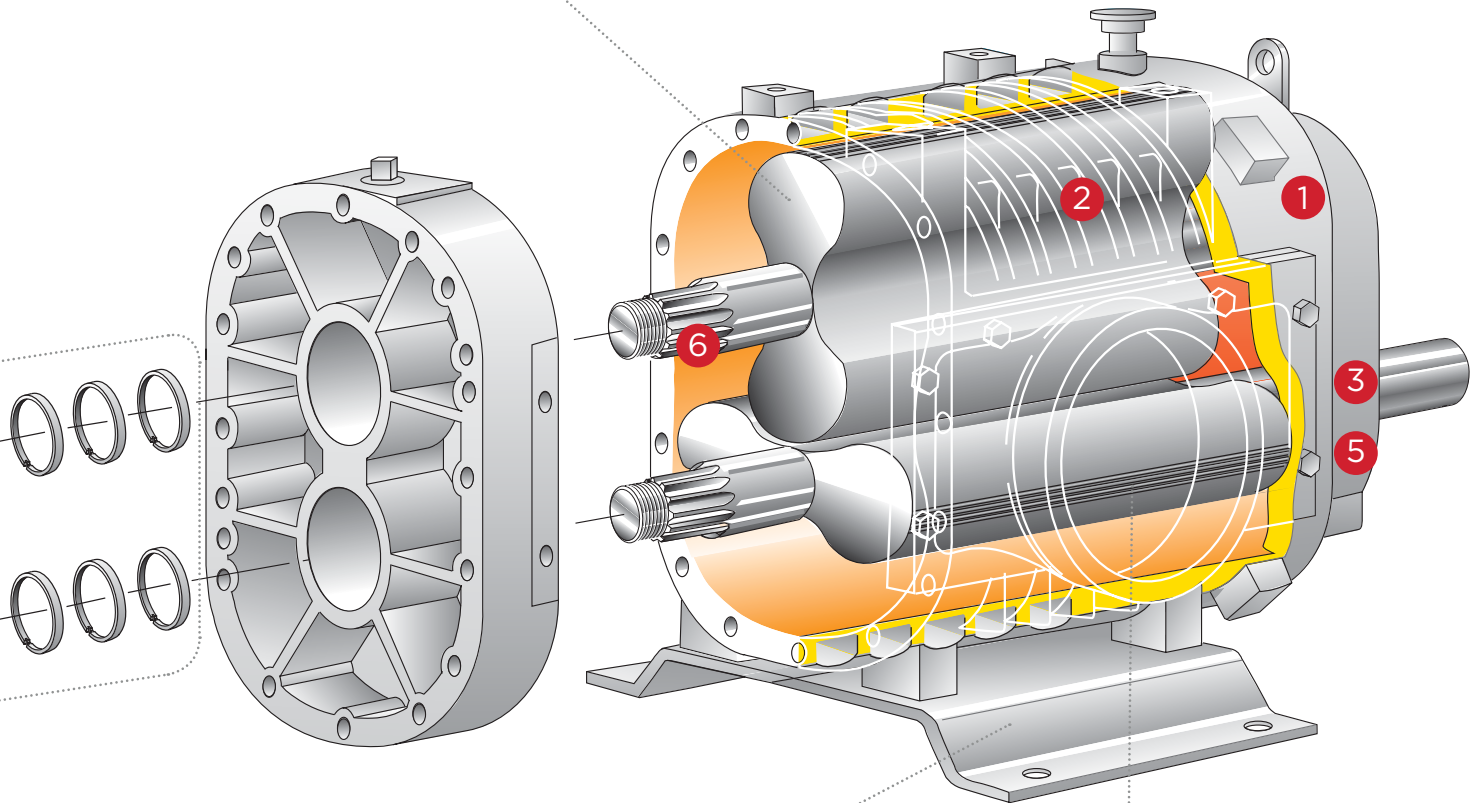

Vertical or Horizontal **Mounting Configuration**

Serrated Tips Reduce Power Consumption



DuroFlow Tough

It's all about...

the RBS SERIES

Available in 29 Sizes

Options

- Stainless Steel Options
- High Vacuum Options
- Force Feed Lubrication
- Pre-Package Availability
- Special Seal Options

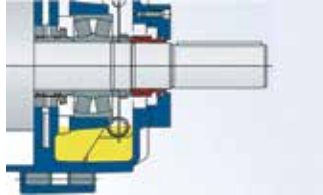

Single Mechanical Seal

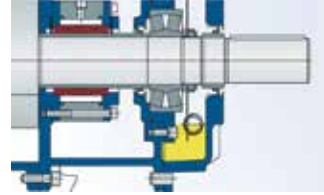

Double Mechanical Seal

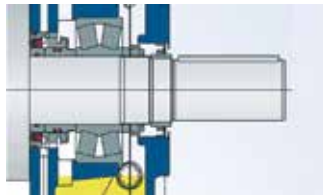

Lip Seal

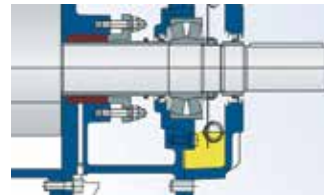

Gland Seal

RBS SERIES

Technology	Specifications		
Tri-Lobe	<p>UP TO</p> <p>14,570 CFM</p> <p>15 PSI</p> <p>15 inHg</p>		

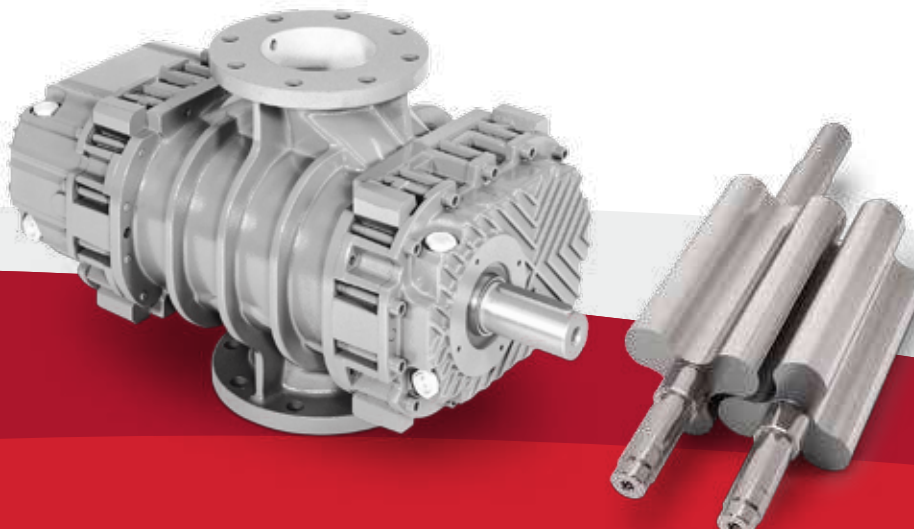

- Solid Tri-Lobe rotors offer quiet, efficient operation
- Robust design for reliability
- Flexible mounting options for easy drop in replacement
- Dual splash lubrication
- 100,000 hour bearing life
- Increased efficiencies

Design Advantages

Dual Splash Lubrication

Reliable dual splash lubrication on both the drive and gear ends for longer product life.

Helical Gears

Helical timing gears for smooth and quiet operation at all speeds.

Leak Free Operation

Piston rings and flinger maximize seal life in continuous severe duty applications.

Durable Shafts

High strength shafts that allow higher operating pressures and rotation speeds.

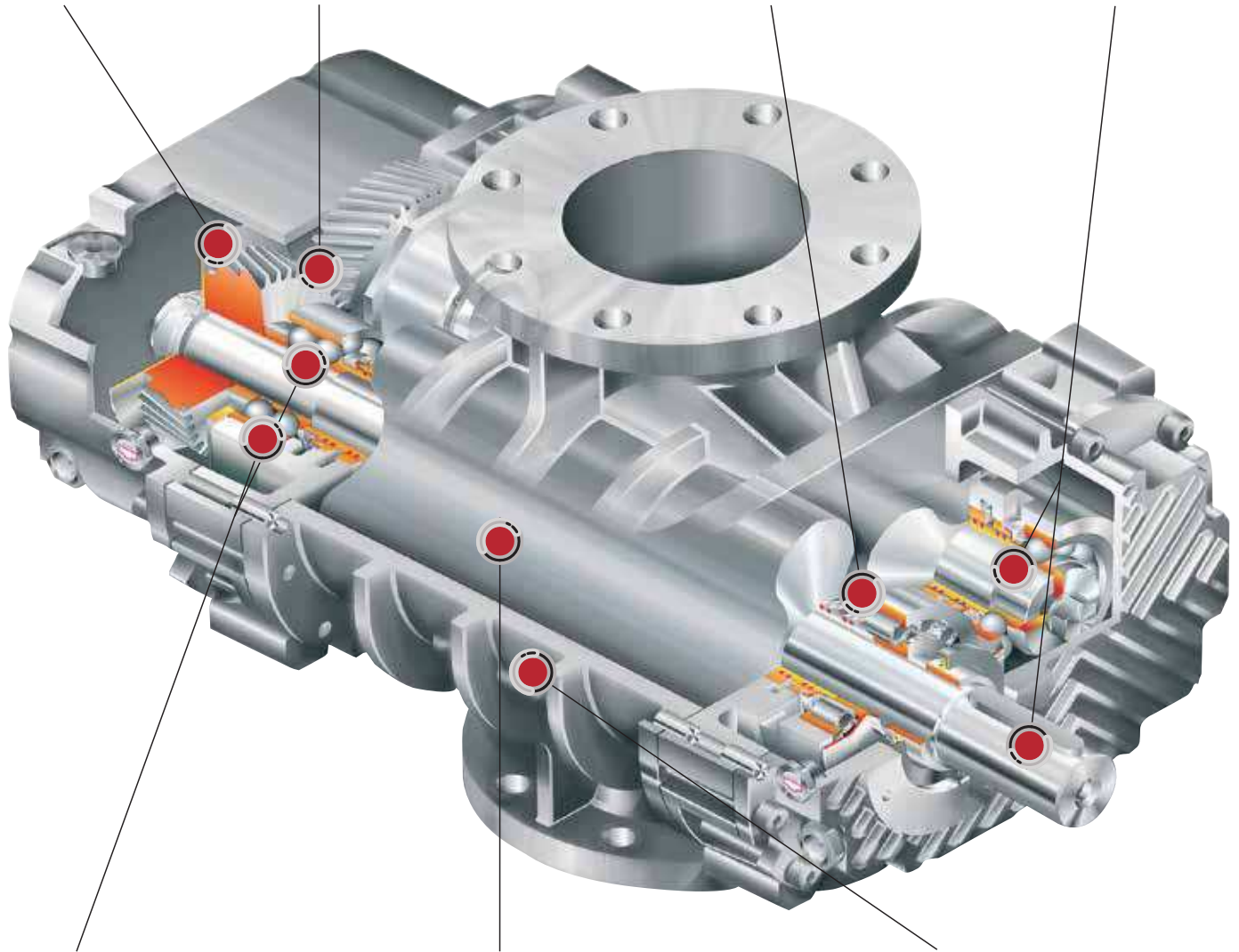

Long Life Bearings

Reinforced roller bearings are calculated for a lifespan of 100,000 hours under the most severe operating conditions.

Three-Lobe Rotors

Involute Three-Lobe Rotors offer the highest performances and efficiencies.

Single Piece Cylinder

High strength impeller case is heavily ribbed and machined from a single piece of cast iron to retain internal clearances and improve heat dissipation.

It's all about...

the HELIFLOW

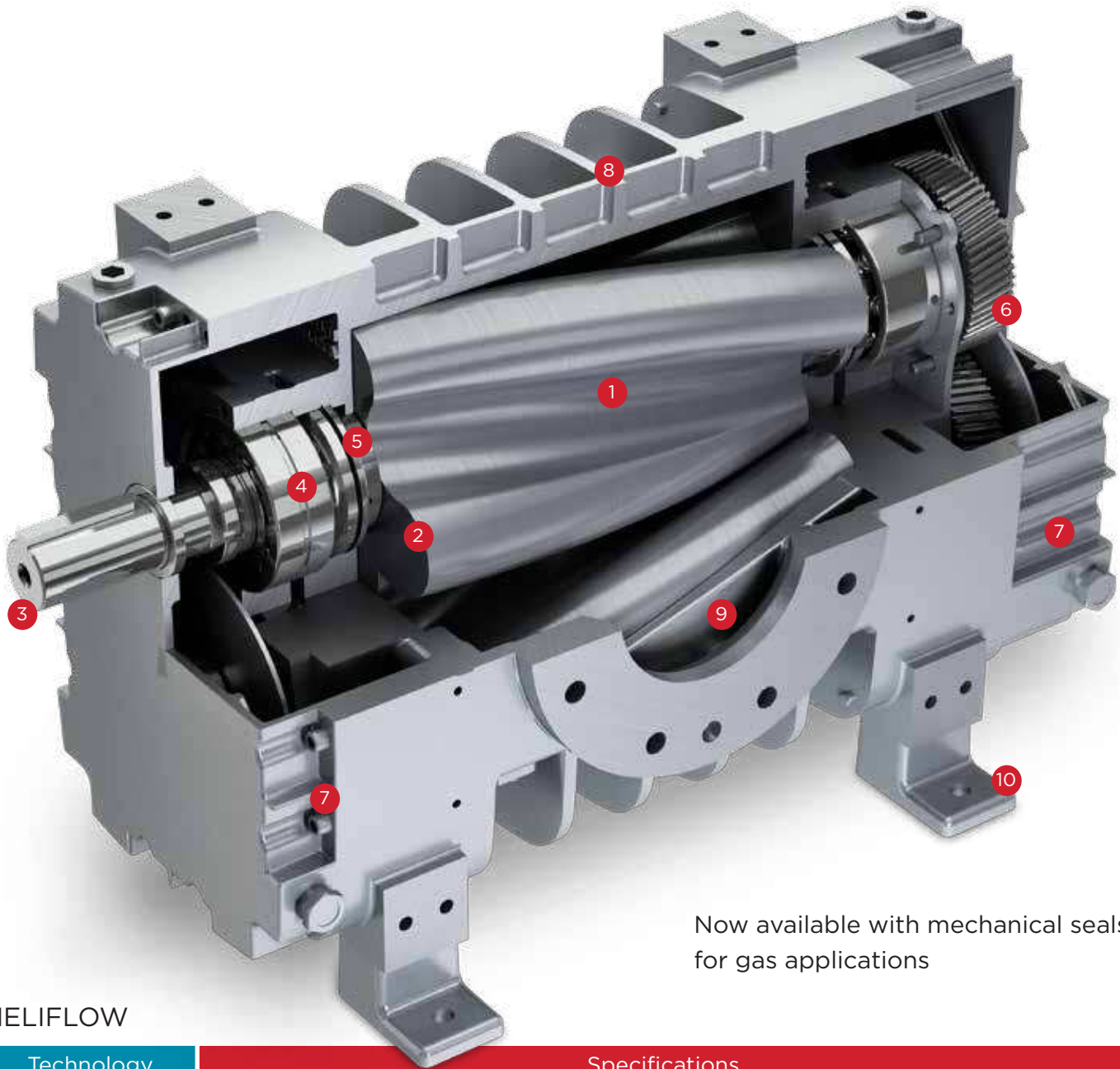

Now available with mechanical seals for gas applications

HELIFLOW

Technology	Specifications
Twisted Tri-Lobe	UP TO 4,800 CFM
	15 PSI
	17 inHg

- 1 Helical rotor profile significantly reduces pulsations for quieter operation
- 2 Solid ductile iron rotor design eliminates potential for vibration due to build-up of ingested material in rotor cavities
- 3 Large diameter shafts provide superior overhung load capacity
- 4 Oversized spherical roller bearings for superior reliability
- 5 Advanced piston ring oil and air seals provide leak-free operation
- 6 Helical alloy steel timing gears provide quiet and smooth mechanical operation at all speeds
- 7 Dual splash lubrication for reduced maintenance intervals and superior durability
- 8 Single piece cylinder with large external fins for heat dissipation and structural integrity
- 9 Unique triangular tuned ports and extra cylinder mass provides greater strength and noise attenuation
- 10 Flexible design allows mounting feet to be attached inward or outward giving it the ability to connect units in a variety of configurations

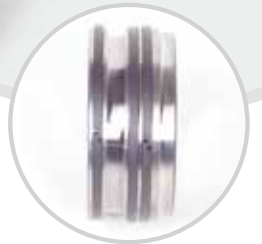

REDUCED PULSE = LOWER NOISE = QUIETER OPERATION

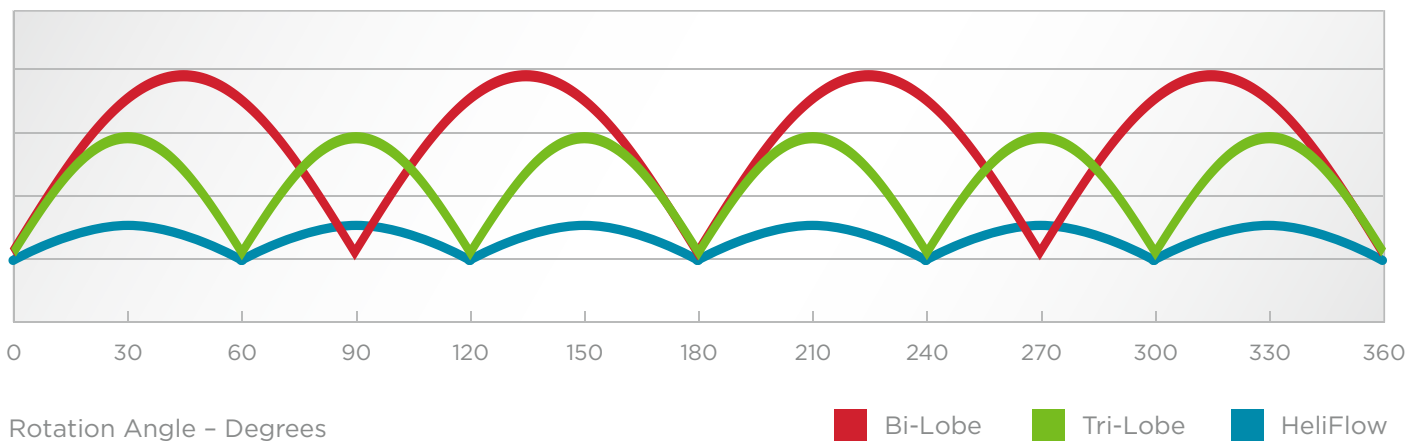

It's all about...

the CYCLOBLOWER

In many comparable applications, the CycloBlower **operates more efficiently** than straight-lobe blowers

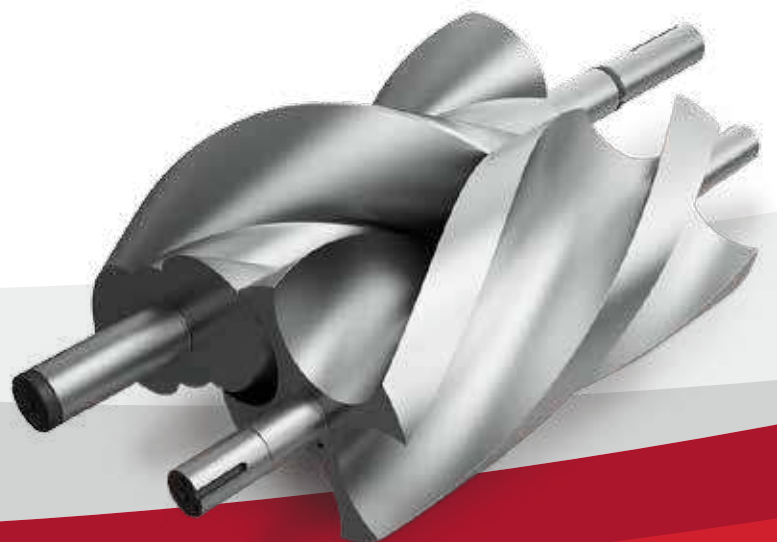
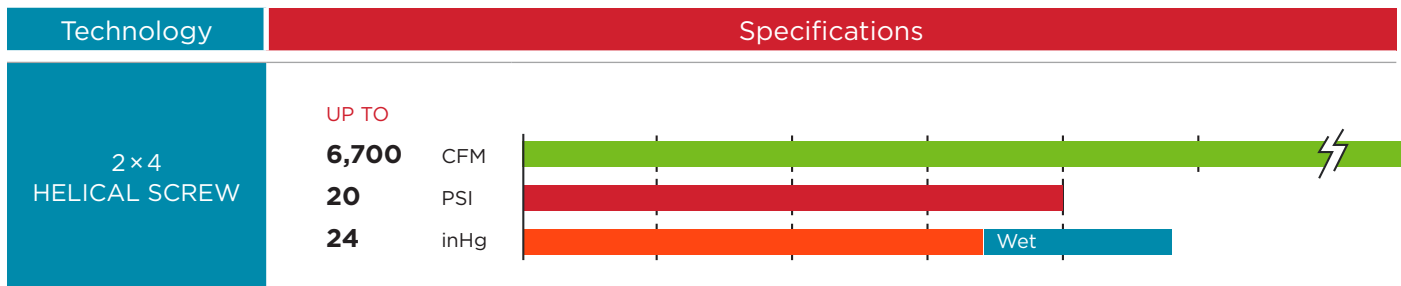

CycloBlower: Unique Screw Design

- Decades of proven results
- Quiet, shock-free compression
- Increased efficiencies over straight lobe blowers
- Dependable quality
- High capacity
- Energy savings made possible by screw design
- Ideal for continuous operation
- Can be used for dense phase applications
- Clean air/gas delivery
- Installation flexibility
- Low cost installation



It's all about...

the CycloBlower H.E.



TOTAL COST OF BLOWER OWNERSHIP

- Energy
 - Maintenance
 - Investment
- Energy consumption is typically the largest cost of ownership
 - Save BIG with best-in-class energy efficiency
 - Lower your bottom line, increase your profits

CYCLOBLOWER® H.E.

Technology	Specifications
3 × 5 HELICAL SCREW	<p>UP TO</p> <p>3,900 CFM</p> <p>36 PSI</p> <p>22 InHg</p>

- Game-changing patented design
- Best-in-class energy efficiency
- Lower your bottom line, increase your profits
- Built with the best-of-the-best components
- Flexible options & installation



BRAKE HORSEPOWER REQUIREMENT COMPARISON
at 2000 CFM

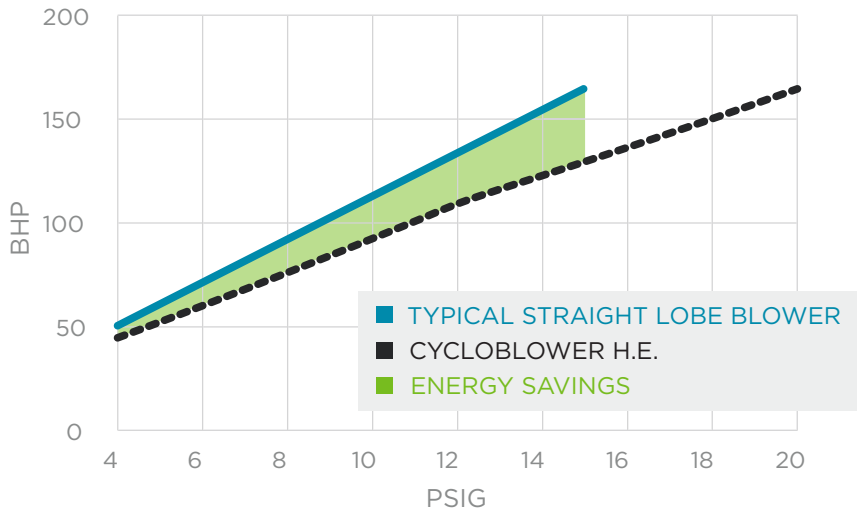

Innovation Working for You!

In many comparable applications, the CycloBlower operates more efficiently than other straight-lobe blowers. By requiring less brake horsepower (BHP) energy operating cost can be realized and greatly reduced.

INVEST WISELY
REDUCE ENERGY

Save Money

CYCLOBLOWER H.E. VS. STRAIGHT LOBE

BLOWER TECHNOLOGY	BHP USED @ 15 PSI	ENERGY COST PER YEAR
Standard Straight Lobe	163	\$106,695
CycloBlower H.E.	129	\$84,604

*Calculations based on the cost of providing 2,000 cfm of air for 8760 hours (1 year of 24/7 operation) assuming motor drive efficiency of 90% and electricity cost of \$0.09/kWh.

\$22,090

ANNUAL SAVINGS



It's all about...

the IQ BLOWER PACKAGES

Gardner Denver has more blower package options than anyone else

We can help you customize your system to meet your needs. More technology designs provides tailored options for you.

- Smart Design
- Easy Maintenance
- Compact Installation
- Quiet Operation
- Enclosed or Unenclosed Available
- Inverter Duty Motors for VFD Capabilities

IQ-RB

SIMPLE

Straight Tri-Lobe

Pressure to 15 PSI

Vacuum to 15 inHg

5,500 Max CFM

3-500 HP

Fixed Speed

Mechanical Gauges



IQ

SMART

Twisted Tri-Lobe
Pressure to 15 PSI
Vacuum to 17 inHg
1,500 max CFM
7.5-100 HP
Fixed Speed or VFD
AirSmart Controller



IQ-HE

EFFICIENT

3x5 Helical Screw
Pressure to 36 PSI
5,625 Max CFM
7.5-500 HP
Fixed Speed
AirSmart G2 Controller



Patented
Rotor Profile
High Efficiency
up to 36 PSI



The leader in every market we serve
by continuously improving all business processes
with a focus on innovation and velocity

Gardner
Denver

Gardner Denver, Inc.

1800 Gardner Expressway
Quincy, IL 62305
866-428-4890

www.gardnerdenver.com/gdproducts



©2017 Gardner Denver, Inc. Printed in U.S.A.
PD-IND-BLOWER 4th Ed. 5/17

