



POSITIVE DISPLACEMENT BLOWERS & VACUUM PUMPS

Water & Wastewater Treatment **Solutions**



Water & Wastewater Treatment Solutions

Gardner Denver understands the complex needs and challenges of the water and wastewater industries and offers a unique range of bare blowers and blower packages known for their excellent performance and low maintenance.

- Energy-efficient rotary screw blowers
- Quiet helical tri-lobe blowers
- High performance straight-lobe blowers
- Pressure to 36 psi
- Air flow to 26,000 cfm

Reliable **QUIET**
ENERGY SAVINGS
EFFICIENT
High Performance



Wastewater Industry Processes

Grit Aeration

- Air is blown into the water, which creates a spiral flow of water
- Particles of a certain size drop to the bottom of the chamber, and are removed
- The wastewater is then moved onto the next process

Channel Aeration

- Air is pumped through diffusers into tanks containing wastewater
- The diffusers create bubbles, raising the level of dissolved oxygen
- The dissolved oxygen promotes the growth of bacteria that help remove the phosphates in the water

Aerobic Digestion

- Process of oxidizing and decomposing organic material, with the presence of oxygen
- Helps reduce mass and volume, as well as harmful micro-organisms
- The most widely used wastewater treatment process for smaller plants

Sludge Digestion

- Digestion process with absence of oxygen
- Transforms organic material into gases, such as methane, which can then be used or sold as an energy source
- The most widely used wastewater treatment process for large plants, over 5 MGD

Filter Backwash

- Air is used to expand the filter bed, breaking up compacted material
- Clean backwash water is pumped in, suspending the loose particles
- The suspended particles are lifted into troughs and carried away



It's all about...

the Complete Package

Gardner Denver has more blower package options than anyone else

We can help you customize your system to meet your needs. More technology designs provides tailored options for you.

- Smart Design
- Easy Maintenance
- Compact Installation
- Quiet Operation
- Enclosed or Unenclosed Available
- Inverter Duty Motors for VFD Capabilities

IQ-RB

SIMPLE

Straight Tri-Lobe

Pressure to 15 PSI

Vacuum to 15 inHg

5,500 Max CFM

3-500 HP

Fixed Speed

Mechanical Gauges



IQ

SMART

Twisted Tri-Lobe
Pressure to 15 PSI
Vacuum to 17 inHg
1,500 max CFM
7.5-100 HP
Fixed Speed or VFD
AirSmart Controller



IQ-HE

EFFICIENT

3x5 Helical Screw
Pressure to 36 PSI
5,625 Max CFM
7.5-500 HP
Fixed Speed
AirSmart G2 Controller



Patented
Rotor Profile
High Efficiency
up to 36 PSI



It's all about the...

Reliable Monitoring



- AirSmart controls available on the IQ and IQ-HE
- Can communicate with various plant control systems including SCADA

Sequence up to Eight Blower Packages

- Can be process or timer operated
- Allows distribution of operating hours
- Reduces downtime for maintenance



CONSTANT MONITORING SEQUENCING MAINTENANCE TIMERS



3 STAGES OF PROTECTION

01

Monitors all functions



02

Sends notice if abnormal event happens



03

Takes Action: Shuts down system & notifies operator if critical threshold is breached



Protection

Constant monitoring with the AirSmart G2 Controller gives you peace of mind by offering the highest levels of protection and functionality to your blower package.

Customizable Maintenance Timers

- Track maintenance schedules
- Notify operator when routine service is required

It's all about...

Saving Money



TOTAL COST OF BLOWER OWNERSHIP

- Energy
- Maintenance
- Investment

- Energy consumption is typically the largest cost of ownership
- Save BIG with best-in-class energy efficiency
- Lower your bottom line, increase your profits

CYCLOBLOWER® H.E.

TECHNOLOGY	SPECIFICATIONS
3×5 HELICAL SCREW	<div style="display: flex; align-items: flex-start;"> <div style="margin-right: 20px;"> <p style="color: red; font-weight: bold;">UP TO</p> <p style="font-weight: bold;">6,200</p> <p>CFM</p> <p style="font-weight: bold;">36</p> <p>PSI</p> <p style="font-weight: bold;">22</p> <p>InHg</p> </div> <div style="margin-right: 20px;"> </div> <div> <ul style="list-style-type: none"> ■ Game changing patented design ■ Best-in-class energy efficiency ■ Built with the best-of-the-best components ■ Flexible options & installation </div> </div>



BRAKE HORSEPOWER REQUIREMENT COMPARISON
 at 2000 CFM

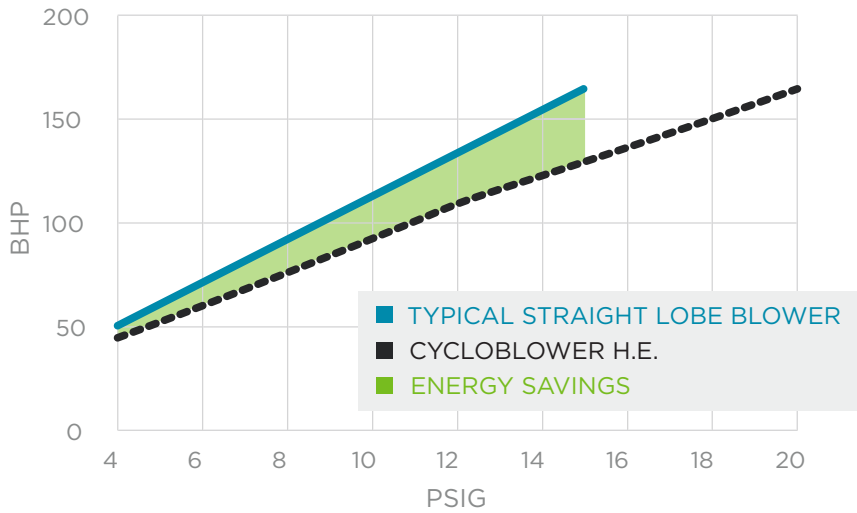

Innovation Working for You!

In many comparable applications, the CycloBlower operates more efficiently than other straight-lobe blowers. By requiring less brake horsepower (BHP) energy operating cost can be realized and greatly reduced.

INVEST WISELY
 REDUCE ENERGY

Save Money

CYCLOBLOWER H.E. VS. STRAIGHT LOBE

BLOWER TECHNOLOGY	BHP USED @ 15 PSI	ENERGY COST PER YEAR
Standard Straight Lobe	163	\$106,695
CycloBlower H.E.	129	\$84,604

\$22,090
 ANNUAL SAVINGS

*Calculations based on the cost of providing 2,000 cfm of air for 8760 hours (1 year of 24/7 operation) assuming motor drive efficiency of 90% and electricity cost of \$0.09/kWh.



It's all about...

Performance

In many comparable applications, the CycloBlower **operates more efficiently** than straight-lobe blowers

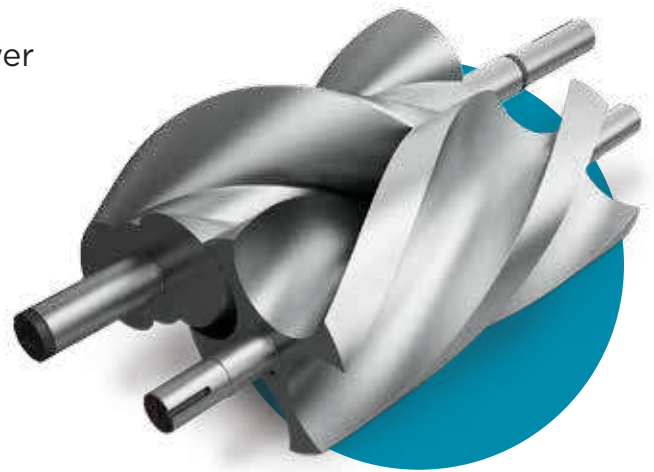

All CycloBlowers are fitted with proprietary bearing isolator seals. Our unique design developed in partnership with Inpro/Seal offers outstanding performance and longevity.

CYCLOBLOWER®

TECHNOLOGY	SPECIFICATIONS	
<p>2x4 HELICAL SCREW</p>	<p>UP TO 6,700 CFM 20 PSI 24 InHg</p>	<ul style="list-style-type: none"> ■ Increased efficiencies over straight lobe blowers ■ Saving Energy = Saving Money ■ Quiet, shock-free compression ■ Built with the best-of-the-best components ■ Ideal for continuous operation

CycloBlower: Unique Screw Design

- Decades of proven results
- Efficient, shock-free compression
- Dependable quality
- High capacity
- Energy savings made possible by screw design
- Ideal for continuous operation
- Can be used for dense phase applications
- Clean air/gas delivery
- Installation flexibility
- Low cost installation



It's all about the...

Quiet Operation

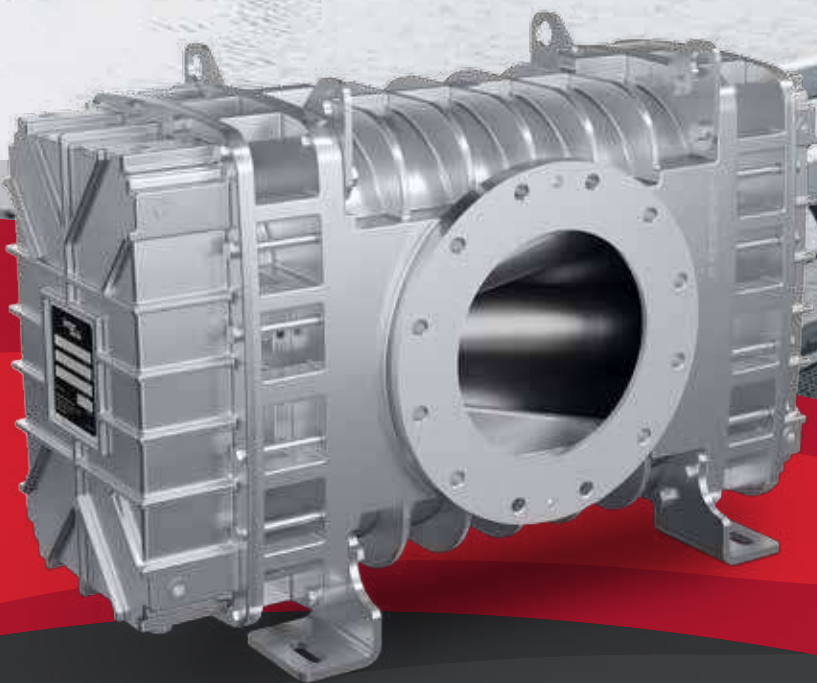

A Strategic Solution,
for Sound Management

CHANGE IN PRESSURE PULSE

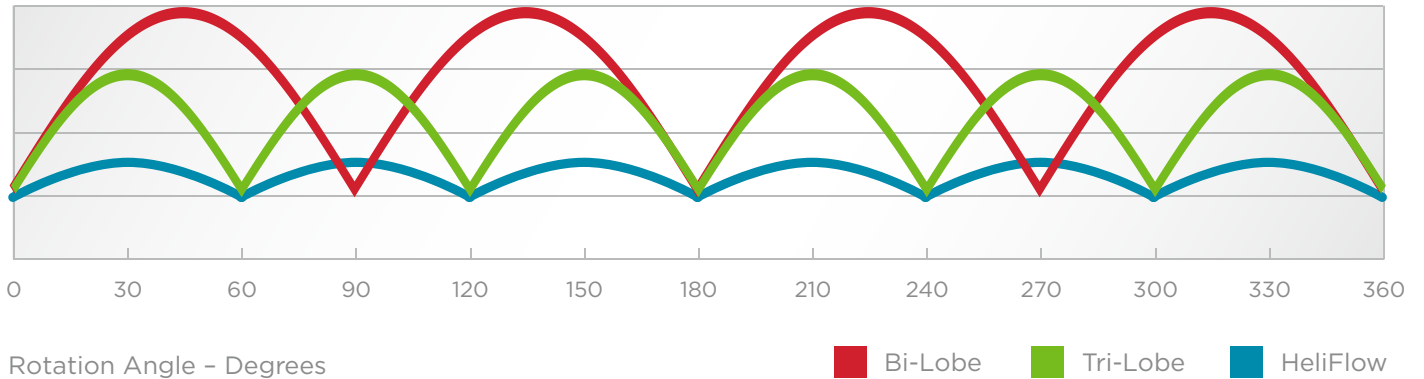

Lower Noise

Discharge pulsation is the chief contributor to high noise levels. HeliFlow provides the lowest pressure pulse in the lobe blower market. This reduces noise levels by 4-7 dBA over similar sized, straight-lobe blowers.

Reduced Pulsations

HeliFlow provides more consistent flow variation, reducing the potential for damage to downstream valves and instrumentation.

Higher Reliability

Discharge pressure pulsation causes axial thrust and higher variations in torque resulting in reduced bearing life. The HeliFlow smooth pulse operation extends the life of the blower.

BACKED BY A
2 YEAR
WARRANTY

From date of initial use or
30 months from date of shipment

HELIFLOW®

TECHNOLOGY	SPECIFICATIONS
TWISTED TRI-LOBE	<p>UP TO</p> <p>4,500 CFM</p> <p>18 PSI</p> <p>17 InHg</p> <ul style="list-style-type: none"> ■ Significant noise reduction over straight lobe technologies ■ Lowest pressure pulses in lobe blower market ■ Quiet, shock-free compression ■ Reduced Pulsations = Quieter Operation ■ Protect your employees hearing and improve safety ■ Increased efficiencies

It's all about...

the RBS Series

AVAILABLE IN 29 SIZES

OPTIONS

- Stainless Steel Options
- High Vacuum Options
- Force Feed Lubrication
- Pre-Package Availability
- Special Seal Options

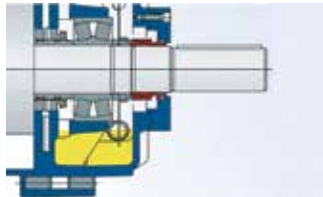

Single Mechanical Seal

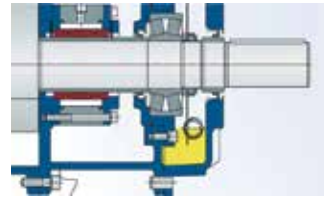

Double Mechanical Seal

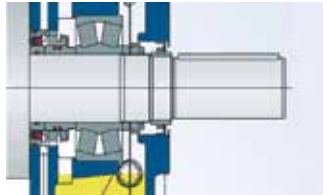

Lip Seal

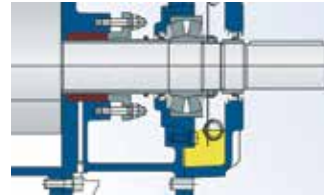

Gland Seal

RBS SERIES

TECHNOLOGY

SPECIFICATIONS

STRAIGHT
TRI-LOBE

UP TO

14,570 CFM

15 PSI

15 InHg



- Solid Tri-Lobe rotors offer quiet, efficient operation
- Robust design for reliability
- Flexible mounting options for easy drop in replacement
- Dual splash lubrication
- 100,000 hour bearing life
- Increased efficiencies

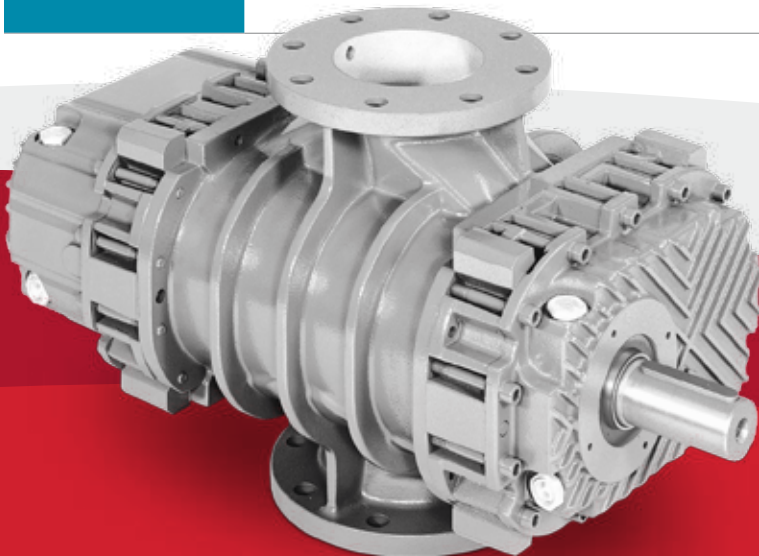

Design Advantages

Dual Splash Lubrication

Reliable dual splash lubrication on both the drive and gear ends for longer product life.

Helical Gears

Helical timing gears for smooth and quiet operation at all speeds.

Leak Free Operation

Piston rings and flinger maximize seal life in continuous severe duty applications.

Durable Shafts

High strength shafts that allow higher operating pressures and rotation speeds.

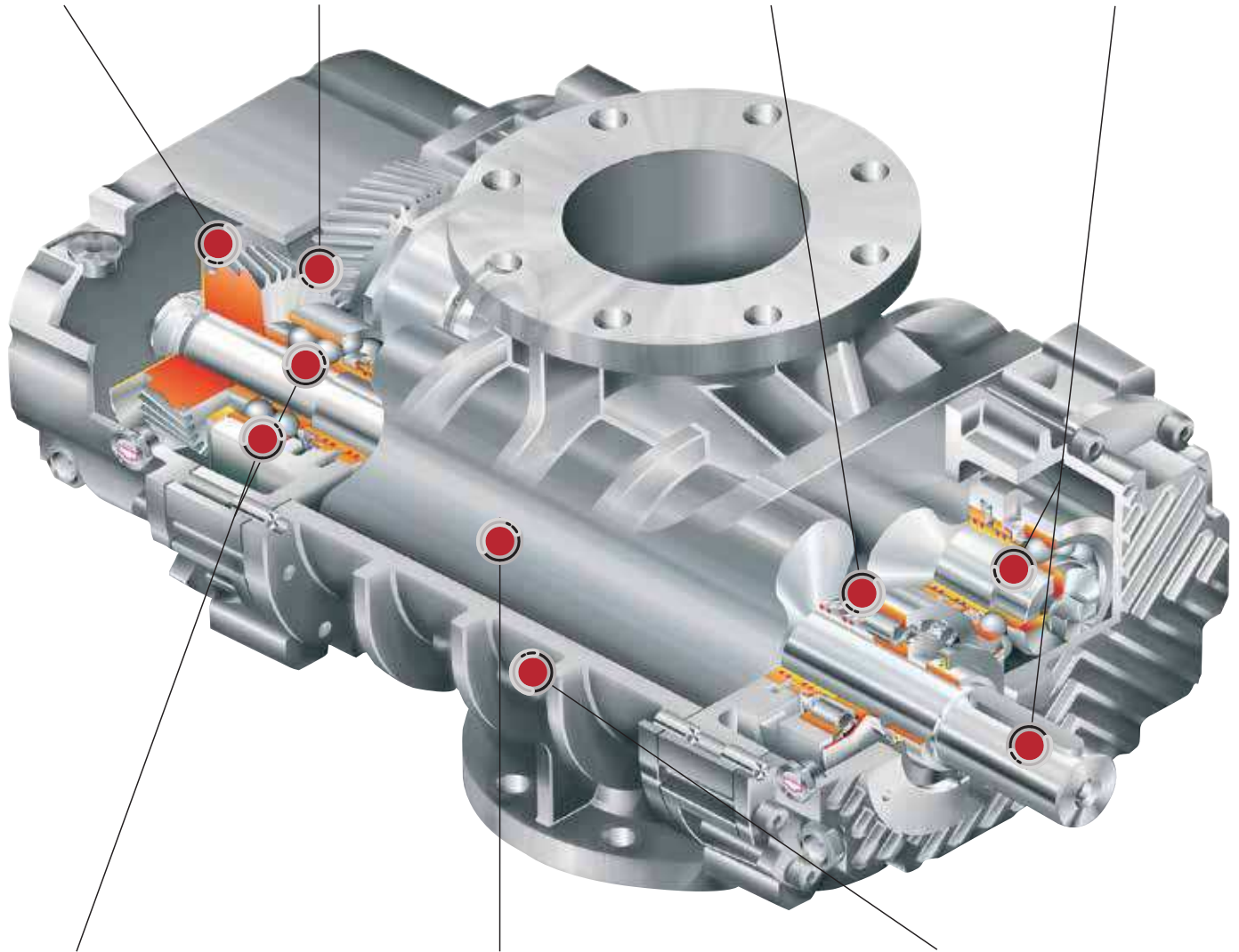

Long Life Bearings

Reinforced roller bearings are calculated for a lifespan of 100,000 hours under the most severe operating conditions.

Three-Lobe Rotors

Involute Three-Lobe Rotors offer the highest performances and efficiencies.

Single Piece Cylinder

High strength impeller case is heavily ribbed and machined from a single piece of cast iron to retain internal clearances and improve heat dissipation.

It's all about...

Legendary Products

SUTORBILT SERIES

TECHNOLOGY	SPECIFICATIONS	
BI-LOBE Sutorbilt®	<p>UP TO 26,000 CFM</p> <p>15 PSI</p> <p>24 InHg</p> 	<ul style="list-style-type: none">■ The most versatile blower available■ Over 240 configuration options■ Grease or dual splash lubrication■ Quiet series option



Sutorbilt Legend

2-8" Gear Sizes

Tried & Trusted for Over 30 Years

- Available dual splash lube
- Optional Q-cylinder for quiet operation
- Universal flex-mount design provides maximum installation versatility
- Low up front cost
- Thousands of units in operation

Sutorbilt 4500, 4800 Series

6-8" Gear Sizes

Setting the Industry Standard

- Rated for continuous duty
- Permits higher speeds and performance ratings
- Advanced case design with increased vent areas
- Heavy duty construction provides longer life

Sutorbilt 8000 Series

10-22" Gear Sizes

Large Air Solutions

- Force feed lubrication available
- Optional Q-cylinder for quiet operation
- One piece steel shafts with dynamically balanced rotors
- Wet vac option



It's all about...

the Network





We're Where You Need Us

Quality Promise

- Gardner Denver industrial blowers are manufactured under rigid ISO 9001 quality standards
- All models are thoroughly tested to meet the highest performance standards for unequalled service life under the most severe operating conditions



Distribution & Service Network

Gardner Denver is proud to offer the most extensive and qualified distributor network available. Local Distributors offer 24-hour service and technical support for all your needs.

Genuine Gardner Denver Parts & Lubricants

- Maintain the Gardner Denver performance advantage and reliability with Genuine GD Replacement Parts available through authorized sales and service representatives
- Protect your Gardner Denver investment with AEON® PD, the only lubricant specially formulated for all blowers in any environment
 - Now Available:
 - >> AEON PD-XD (extreme duty)
 - >> Designed specifically for high ambient and high discharge temperature applications
 - Also Available:
 - >> AEON PD (standard applications)
 - >> AEON PD-FG (food grade)



Gardner Denver®

Gardner Denver, Inc.

1800 Gardner Expressway
Quincy, IL 62305
866-428-4890

www.gardnerdenver.com/gdproducts



©2017 Gardner Denver, Inc. Printed in U.S.A.
PD-APP-WW 10th Ed. 9/17

Please recycle after use.