

# VECTOR

## PERISTALTIC PUMPS

Designed to Handle Difficult Fluids



## For Processing Applications with Difficult Fluids

<b>Contents</b>	<b>Page</b>
Introduction .....	3
Capabilities Overview	
Flow Capacities & Pressure Ratings.....	4
Maximum Allowable Solids Guidelines.....	4
Performance Advantages.....	6
Industries Served & Fluids Pumped.....	8
Operating Principle.....	10
Pump Models (2000 & 3000 Series)	
Hose Data.....	12
Selection Criteria .....	13
2002 .....	14
2003 .....	16
2004 .....	18
2005 .....	20
3005 .....	22
2006 .....	24
2007 .....	26
2008 .....	28
2009 .....	30
2010.....	32
Pump Models (4000 Series)	
Hose Data.....	34
Selection Criteria .....	35
4003 .....	36
4004 .....	38
4006 .....	40
4007 .....	42
4009 .....	44
4010 .....	46
4014.....	48
Accessories.....	50
Other Wanner Engineering Pumps.....	54

*Due to continuous improvement practices, specifications and other data in this catalog are subject to change.*

# Vector Pumps Handle Aggressive or Corrosive Fluids, High-viscosity Fluids, and High-purity Solutions

Available in 17 models to handle a wide range of processing requirements, Vector peristaltic pumps are ideal for pumping challenging fluids without altering their composition. They move high-viscosity (up to 100,000 cps) pasty, pulpy, thick, abrasive, and corrosive solutions as well as fluids containing solids up to 3-1/2 inches (90 mm) in size.



*Vector pumps isolate the fluid being pumped into a single, durable hose so they can handle tough fluids.*

## Design Features

- Dry pump cavity
- Self-priming operation
- Runs dry without damage
- Complete isolation of fluid pumped
- Heavy-duty roller bearings
- Variety of pump configurations, flows, and pressure ratings
- No dynamic seals, cups or packing to leak or wear
- Reversible flow
- Low maintenance

## Typical Substances Handled

- Acids
- Bentonite Slurries
- Carbon Slurry
- Ceramic Slip
- Cosmetics & Creams
- Dyes & Inks
- Eggs
- Ferric Chloride
- Flavorings
- Iron Oxide Pigments
- Jams & Preserves
- Lime Slurries
- Paint
- Sewage
- Sodium Hydroxide
- Shampoos
- Yogurt

## Typical Industries Served

- Ceramics
- Chemical Processing
- Cosmetics
- Food & Dairy Processing
- Marine
- Mining
- Paints & Coatings
- Petrochemicals
- Pharmaceuticals
- Pulp & Paper
- Water & Wastewater Treatment

# Vector Peristaltic Pumps Capabilities Overview

## Flow Capacities and Pressure Ratings

Model	Maximum Flow (gpm)	Maximum Discharge Pressure (psig)
2002	0.3	30
2003	0.94	30
2004	2.52	45
2005	5.9	50
3005	9.2	200
2006	14.1	60
2007	40.5	100
2008	50	100
2009	120	100
2010	211	116

Model	Maximum Flow (gpm)	Maximum Discharge Pressure (psig)
4003	0.79	110
4004	2.64	110
4006	12.33	218
4007	23.12	218
4009	41.83	218
4010	69.35	218
4014	154.10	218

## Maximum Allowable Solids Guidelines

Pump Model	Hose I.D. (mm)	Non-Compressible Solids		Sharp Solids	Compressible Solids (mm)
		Size of solids, when percentage of solids is >50% (mm)	Size of solids, when percentage is <10% (mm)		
2002	9	1.35	2.25	AVOID	8.1
2003	13	1.95	3.25	AVOID	11.7
2004	17	2.55	4.25	AVOID	15.3
2005	25	3.75	6.25	AVOID	22.5
3005	25	3.75	6.25	AVOID	22.5
2006	30	4.50	7.50	AVOID	27.0
2007	45	6.75	11.25	AVOID	40.5
2008	53	7.95	13.25	AVOID	47.7
2009	75	11.25	18.75	AVOID	67.5
2010	100	15.00	25.00	AVOID	90.0
4003	10	1.35	2.25	AVOID	8.5
4004	15	2.10	3.90	AVOID	14.5
4006	25	3.75	6.25	AVOID	22.5
4007	32	4.50	7.50	AVOID	28.0
4009	40	6.10	10.90	AVOID	39.5
4010	51	7.50	12.90	AVOID	46.5
4014	80	12.10	19.50	AVOID	69.5

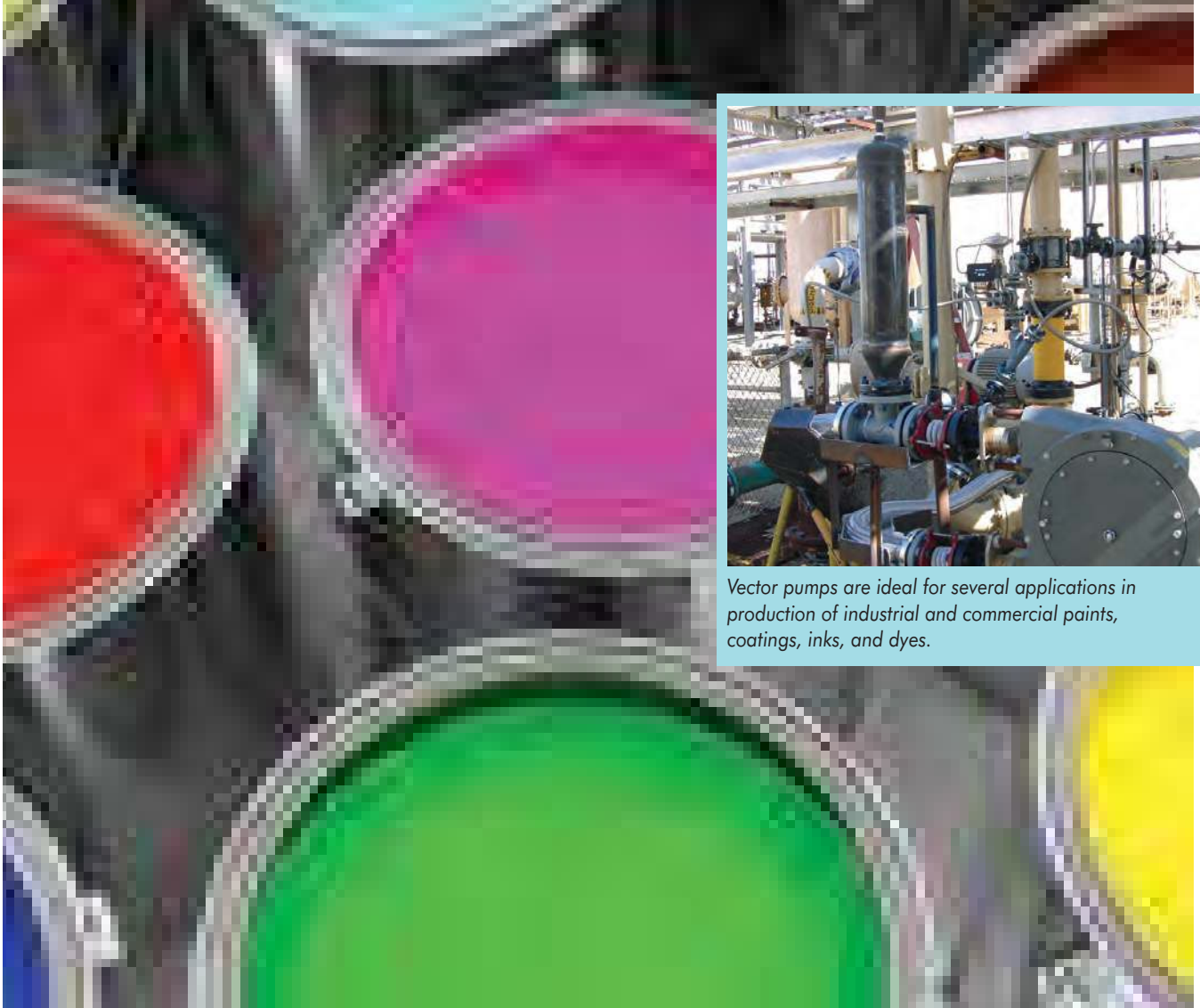

*Vector pumps are ideal for several applications in production of industrial and commercial paints, coatings, inks, and dyes.*

## Vector Pump Performance Advantages

### Pressure Ratings

Up to 218 psig discharge pressure

### Flow Capacities

Up to 211 gpm

### Contamination-free Pumping

Fluid is contained in the hose and only contacts the hose

### Fluid/Hose Compatibility

Fiber-braided or extruded hoses can handle abrasive or corrosive fluids as well as food products or pharmaceutical materials

### Low-shear/Non-emulsifying

Transfers food and pharmaceutical solutions without crushing or foaming the fluids

### Self-priming

Requires no priming chamber; suction lifts to 29-1/2 feet depending on model

### Dry Running

Externally lubricated hose enables the pumps to run dry without stalling or damaging the hose or roller assembly; avoids pump failure and reducing pump life

### Dependable Seal-less Design

No dynamic seals or packing that can leak, clog, wear out, or need replacement

### Handles Abrasive Solids

Can pump abrasive fine particles and solids up to 3-1/2 inches (90 mm)

### Easy to Clean

Reversible rotary movement provides for easy-to-clean system piping; flushing may be eliminated

### Easy to Service

Simple replacement of hoses saves time; clear plastic cover allows the pump to be checked easily during operation for any problems

### Vacuum Capability

A Vector pump can be used as a vacuum pump and for cleaning up spills; evacuates gases as well as fluids

### Dosing Capability

A Vector pump is also a positive displacement pump for metering; output flow is directly proportional to pump speed



*Expensive chemicals and compounds, including adhesive resins, polymers, and latex are protected by Vector pumps during processing.*



## Industries Served and Fluids Pumped

Vector peristaltic pumps can handle the most difficult process fluids to serve a wide range of commercial, institutional, industrial, and municipal markets. Examples of many successful applications are listed in this section - but these are not limitations. If you have a difficult fluid to process not listed, contact Wanner Engineering for application assistance.



### Building & Construction

Adhesives, dyes, glues, grout, iron oxide pigments, paints, plaster, pottery, tile

### Ceramic & Glass

Clay slips, dyes, enamels, glazes, grinding water, grout, quartz paste, silicon

### Chemical Processing

Abrasive mixes, acids, adhesive resins, caustic soda, detergent paste, latex, pigments, polyester mixes, polymers

### Distilleries

Alcohol, spices, spirits

### Electrical

Polyester slurries for insulating wire

### Food & Beverage Processing

Bentonite and carbon slurries, butter, cake dough, cake frosting, caramel, chocolate, cream, egg yolks with whites, fats, flavorings, fruit juices, gelatins, ice cream, jams and preserves, milk, mustard, potato waste, syrups, tomato sauce, water and salt mixtures, yeast solution, yogurt

### Marine

Sewage, wastewater, solid waste

### Meat Processing

Acids, animal and waste blood, hair and bone mixtures

### Medical, Pharmaceutical & Cosmetics

Face creams, latex, lotions, plasma, protein solutions, shampoo, vaccines, Vaseline

### Mining, Tunneling & Quarrying

Coal, copper and platinum slurries

### Photographic

Acids, diluents, thinners

### Pulp & Paper

Abrasive, fibrous fluids, aluminum sulfate, boiler wastewater, caustic soda (lye), cold seal, dyes, hydrochloric acid, inks, pre-paint coatings, sulfuric acid

### Tanneries

Acids, dyes, ferrous sulfate, waste fluids with solids

### Textile Manufacturing

Acids, adhesives, bleach, dyes, sizing

### Water & Wastewater Treatment

Acids, activated carbon, aluminum sulfate, caustic soda (lye), ferrous chloride, flocculants, foam inhibitors, lime slurries, solid waste



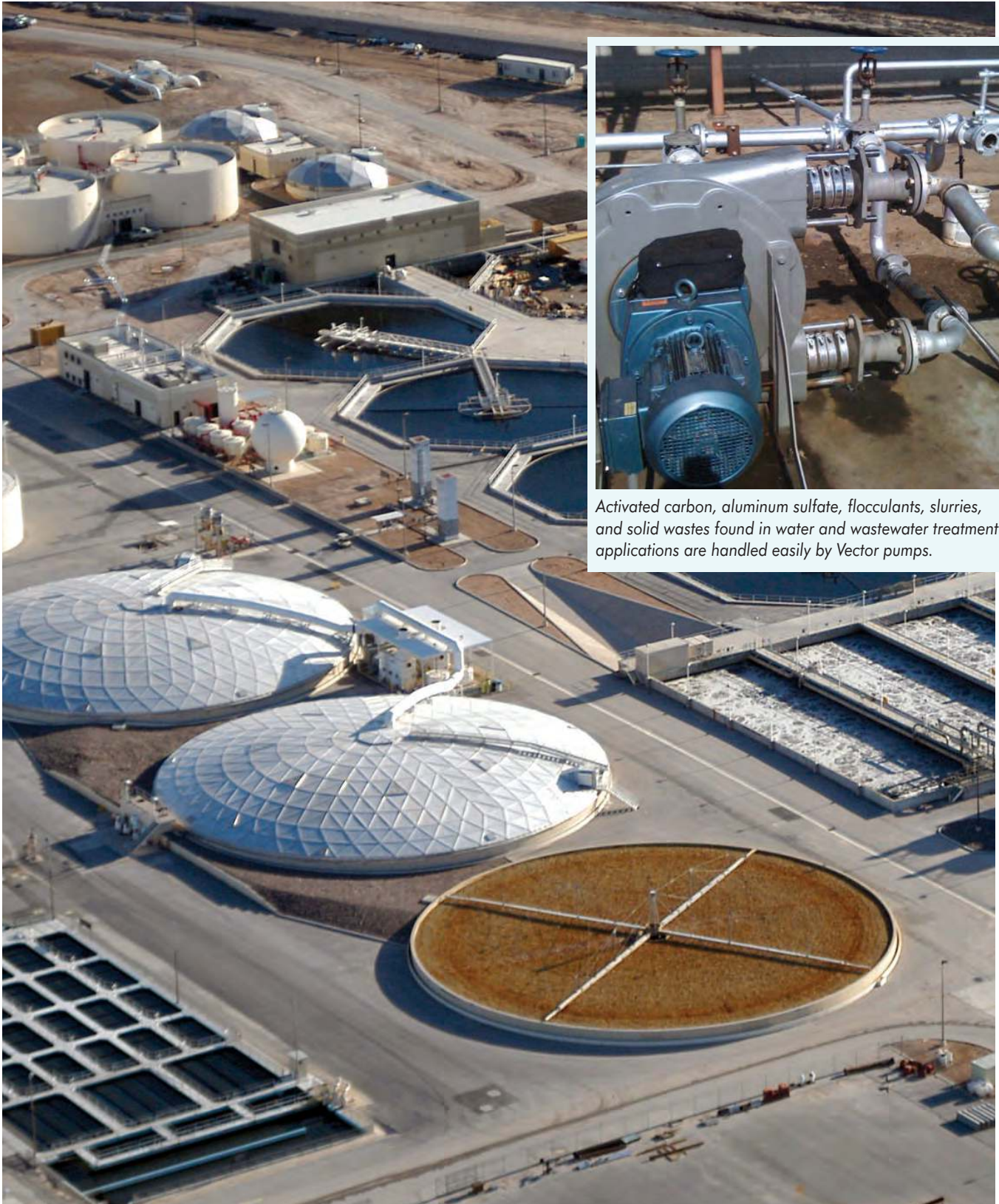

Activated carbon, aluminum sulfate, flocculants, slurries, and solid wastes found in water and wastewater treatment applications are handled easily by Vector pumps.

## Vector Peristaltic Pump Operating Principle

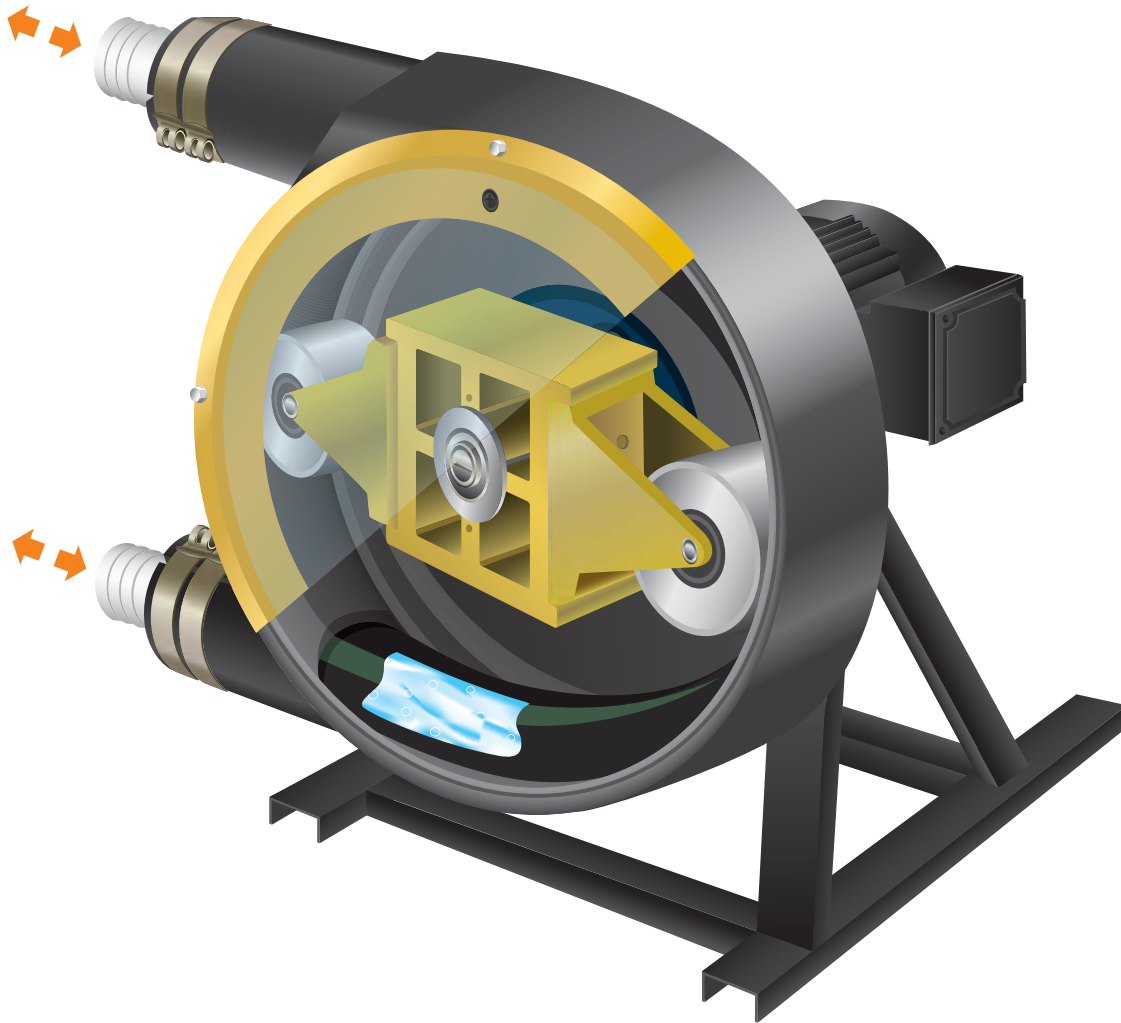

Peristaltic pumps work by compressing and relaxing a hose positioned between a rotating device and a circular pump housing. Vector 2000 Series pumps use rotating rollers that provide the same “push” with far less hose wear.

The peristaltic method employed in Vector pumps can create 100% compression at all times. As a result, there is virtually no slipping. Metering is highly accurate. Up to 29-1/2 feet of suction lift is produced.

Despite this powerful pumping action, Vector pumps will not cause frothing or delicate emulsions to break up. Since fluids travel through a single hose, they never come into contact with moving valves, springs, or seals. This makes Vector pumps ideal for handling abrasive, shear-sensitive, or corrosive fluids. Dyes, thick fluids, and solids up to 3-1/2 inches (90 mm) are also readily pumped.

## Superior Roller Design



Vector uses an evolutionary roller mechanism instead of a rigid shoe to push fluids through its hose. This ensures longer working life with less downtime for maintenance.

The rollers generate less friction than shoes, extending hose life and reducing downtime.

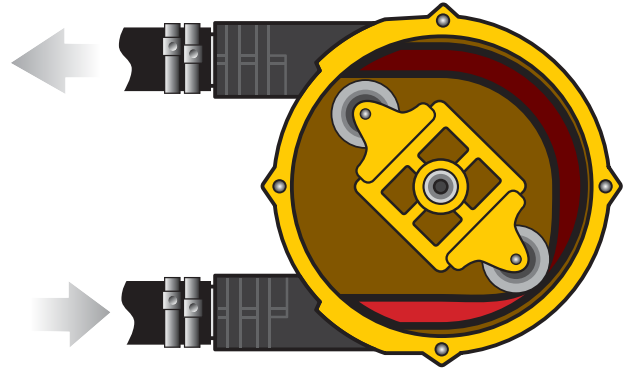

*Fluid positioned ahead of the rollers gets pushed forward as the rollers rotate inside of the case.*

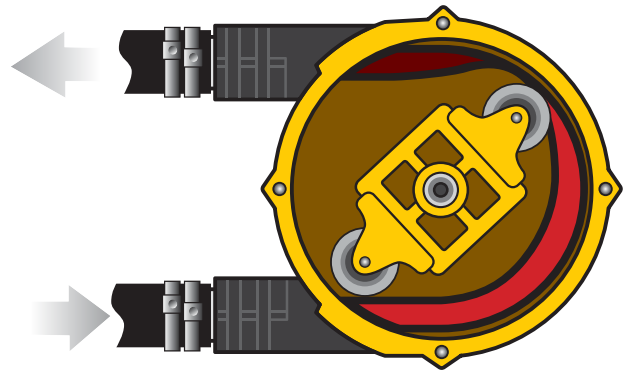

*Meanwhile, the portion of the hose just behind the rollers rebounds to create a vacuum.*

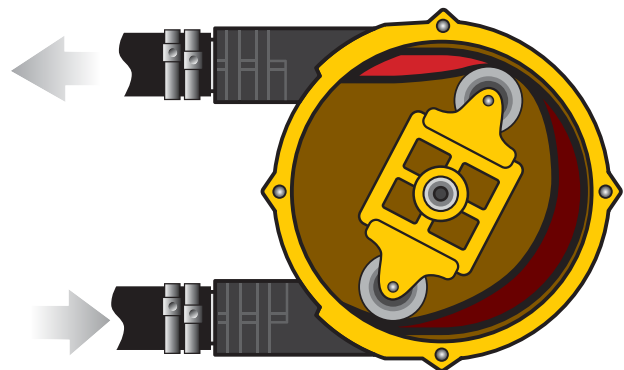

*The vacuum draws fluid into the pumping hose, which is then pushed forward by the rollers.*

## Vector Pumps Hose Data (2000 & 3000 Series)

### Construction

#### Extruded:

- 700-1000 hours Typical Life at 30 rpm  
Preferred when:
- Pumping foods and pharmaceuticals
  - Clean fluids
  - Lower pressures required (max. 30 psig)

#### Fiber Braided:

- 1500-2000 hours Typical Life at 30 rpm  
Preferred when:
- Pumping fluids with abrasives
  - The pump is required to create a strong vacuum
  - High pressures are required

### Operating Duty

**Intermittent:** (One hour stop after 2 hours in use)  
Higher pressures and higher pump speed

**Continuous:**  
Low pressures and lower speed

### Dimensions

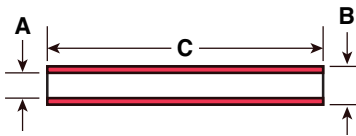

(mm)	A	B	C
2002	9	16	330
2003	13	22	390
2004	17	31	590
2005	25	43	860
2006	30	55	1150
2007	45	75	1455
2008	53	88	1850
2009	75	120	2400
2010	100	144	3250
3005	25	44	850

### Hose Identification

#### Extruded

Material	Code	Description
Hypalon	HE	Black color, shiny smooth surface
Neoprene	PE	Flat black color, rough surface, rubber smell
Varprene	VE	Cream, smooth surface
Silicone	SE	Rust color, smooth surface
Pharmed®	FE	Cream color, Pharmed® name on hose

#### Fiber Braided

Material	Code	Description
Hypalon	HF	Black color, yellow or blue stripe, double braided
EPDM	EF	Black color, white stripe, double braided
Natural Rubber	NF	Black color, green stripe, double braided (standard duty)
Natural Rubber	MF	Black color, no stripes, thick double braids (heavy duty)
Nitrile Rubber	BF	Black color with white inner hose.
Nitrile Rubber, Oil-rated	OF	Black color with HBRF-HY-K stamped on hose.

Material	Operating Temperatures	Industry Approvals
EPDM	32° to 185° F (0° to 85°C)	
Hypalon	32° to 180° F (0° to 82.2°C)	
Neoprene	50° to 130° F (10° to 54.4°C)	
Silicone	14° to 185° F (-10° to 85°C)	
Varprene	14° to 185° F (-10° to 85°C)	Meets FDA Criteria
Natural Rubber <sup>1</sup>	14° to 185° F (-10° to 85°C)	Meets FDA Criteria <sup>1</sup>
Nitrile Rubber, Oil-rated	23° to 160° F (-5° to 71.1°C)	
Pharmed®	32° to 180° F (0° to 82.2°C)	Meets USP Class VI, FDA, and NSF Criteria

<sup>1</sup> Natural rubber heavy duty hose meets FDA criteria.

® Pharmed Reg. Saint-Gobain Performance Plastics

### ATTENTION!

When operating within 15°F (9.4°C) of maximum hose temperature, do not exceed 20 rpm pump speed. In addition, metal inspection plate is required vs. clear plastic material.

# Vector Pumps Selection Guidelines (2000 & 3000 Series)

## 1. Collect application information

Fluid: \_\_\_\_\_

Discharge Press: \_\_\_\_\_ psig

Suction Condition:

Lift: \_\_\_\_\_ feet  
 or Vacuum: \_\_\_\_\_ inches of Hg  
 or Flooded: \_\_\_\_\_ feet of fluid above pump  
 or Pressurized: \_\_\_\_\_ psig

Flow or Flow Range: \_\_\_\_\_ gpm

Temperature (°F): Min: \_\_\_\_\_ Max: \_\_\_\_\_ Normal: \_\_\_\_\_

Solids?, describe: \_\_\_\_\_

Solid Size: \_\_\_\_\_

Solid Length: \_\_\_\_\_

Solids %: \_\_\_\_\_

Viscosity at Temp: \_\_\_\_\_

Vapor Pressure at Temp: \_\_\_\_\_

Specific Gravity: \_\_\_\_\_

Duty Cycle (hrs/day): \_\_\_\_\_

Motor Enclosure: \_\_\_\_\_

Hertz: 50 \_\_\_\_\_ 60 \_\_\_\_\_

Volts: \_\_\_\_\_

Phase: 1 \_\_\_\_\_ 3 \_\_\_\_\_

Motor eff: Std \_\_\_\_\_ High \_\_\_\_\_ Inverter Duty \_\_\_\_\_

Variable Frequency Drive: Yes \_\_\_\_\_ No \_\_\_\_\_

If yes, what environment will controller be mounted:

Inside another panel \_\_\_\_\_ Dry, fairly dust free \_\_\_\_\_

Dusty area \_\_\_\_\_ Wet area \_\_\_\_\_

Wash down area \_\_\_\_\_

Hazardous area \_\_\_\_\_ If yes, class and group \_\_\_\_\_

If Yes, input voltage: 120 \_\_\_\_\_ 230 \_\_\_\_\_ 460 \_\_\_\_\_

## 2. Determine the maximum roller speed

### Duty Cycle (hours/day) of operation

- <8 hours/day: the pump can be run out of the gray shaded areas on the pump specification curves (minimum of 1 hour stop after 2 hours use).
- 8-12 hours/day: do not operate out of the gray shaded areas on the pump specification curves.
- >12 hours/day: 25-32 rpm is the maximum recommended speed.

### Viscosity of the fluid

- <200 cps: no speed correction needed
- 200-1000 cps: max. speed 40 rpm
- 1,000-5000 cps: max. speed 30 rpm; use flooded/pressurized suction
- 5,000-10,000 cps: max. speed 20 rpm; use flooded/pressurized suction
- 10,000-15,000 cps: max. speed 10 rpm; use flooded/pressurized suction

Note: With viscosities over 200 cps it is very important to oversize the suction line 1-1/2 to 2 times the pump connector size and to keep suction lines as short as possible.

**Temperature of the fluid:** If the fluid temperature pumped is within 15° F (9.4°C) of the maximum temperature rating of the hose, contact factory and select a pump with a maximum speed of 20 rpm.

## 3. Pump Selection

- Select pump that can deliver the required flow based on the maximum roller speed and discharge pressure required by the application.

Note: It may be required to select a larger pump if solids are larger than the maximum size the pump can handle.

## 4. Hose Selection

- Hose selection based on chemical compatibility and temperature.
- For suction vacuum over 4.5" Hg, always use fiber braided hoses (extruded hoses may collapse)
- In general, fiber-braided hoses will last longer and withstand greater discharge pressures than extruded hoses.
- Maximum recommended motor speeds with extruded hoses 40 rpm.

Note: Maximum viscosity for Nitrile hose is 3000 cps.  
 (The inner white hose will separate from the outer black hose.)

## 5. Connector Type and Material Selection

## 6. Drive Selection

## MODEL 2002 PUMP DATA

### Performance

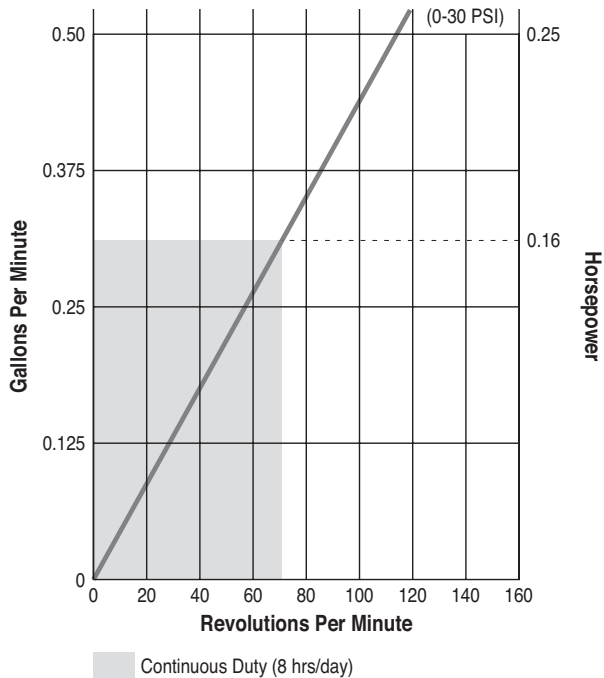

### Fluid Characteristics

Viscosity:	15,000 cps max.
Liquid Temperature:	180°F (82°C) max.
Solid Size:	(see page 4)
Fiber Length:	1/4 inch (6.3 mm) max.

### Specifications

Discharge Pressure:	30 psig (2 bar) max.
Suction Lift:	7 ft (2.1 m)
Suction Pressure:	15 psig (1 bar) max.
Horsepower*:	1/4 max.
Hose Size:	9 x 16 x 330 mm
Displacement:	0.0044 gal/rev
Weight (pump only):	6.5 lbs (3 kg)
Weight (with drive):	15.2 lbs (7 kg)

\* Pumps are shaft driven and require a gearbox and motor.  
See Ordering Information on following page for details.



### Materials of Construction

#### Non-wetted Parts

Casing: Aluminum Alloy  
Rotor: Aluminum Alloy  
Rollers: Plastic/Alloy

#### Wetted Parts

Hose:

EXTRUDED – Neoprene, Hypalon, Varpene, PharMed®  
BRAIDED – Natural Rubber, EPDM

Inlet/Outlet Connections:

PTFE, Brass or Stainless Steel Hose Barb, Brass NPT, and  
Stainless Steel Sanitary Tri-clamp

## Dimensional Drawings

Inches (mm)

See Ordering Information for motor and gearbox sizes.

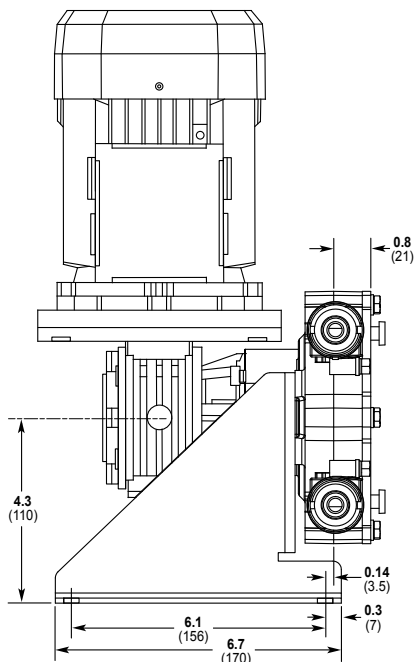
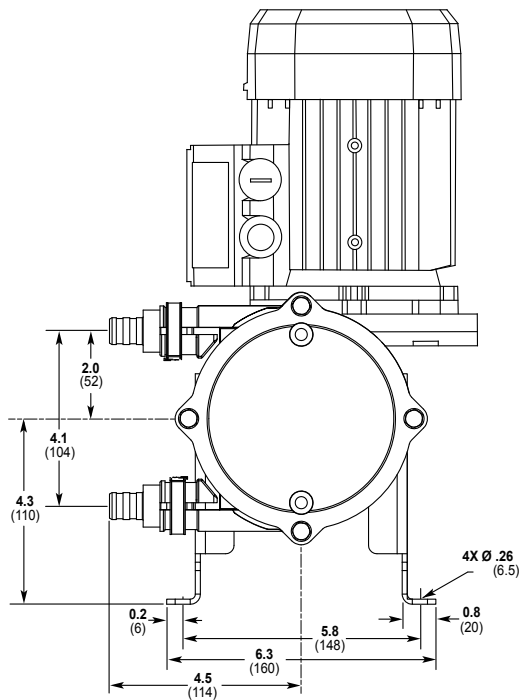

## Model 2002 Ordering Information

A complete Vector pump order number uses a 10-character order code to identify the desired hose, fittings and drive. Select the appropriate items from the chart below and use the order code from each group to complete the pump assembly order number.

<b>1</b>	<b>2</b>	<b>3</b>	<b>4</b>	<b>5</b>	<b>6</b>	<b>7</b>	<b>8</b>	<b>9</b>	<b>10</b>
2	0	0	2						

Order Digit	Order Code	Description			
<b>1-4</b>	<b>2002</b>	<b>Pump Designation</b> Model 2002 Shaft Drive Pump			
<b>5-6</b>		<b>Hose Material/Type</b>			
	FE	PharMed®, extruded <sup>(1)</sup>			
	HE	Hypalon, extruded			
	NF	Natural Rubber, fiber-braided			
	EF	EPDM, fiber-braided			
	PE	Neoprene, extruded			
	VE	Varprene, extruded			
<b>7-8</b>		<b>Connector Material/Style</b>			
	AA	PTFE, 1/2" hose barb			
	CC	316 SST, Sanitary, 3/4" tri-clamp			
	FF	Brass, 3/8" hose barb			
	GG	Brass, 3/8" male NPT			
	SS	316 SST, 3/8" hose barb			
	TT	316 SST, 3/8" male NPT			
<b>9-10</b>		<b>Drive</b>			
		<b>Flow GPM</b>			
		<b>Gear Ratio</b>			
		<b>Pump RPM</b>			
		<b>Max Psig</b>			
		<b>1Ø, 1/4 BHP TEFC, 115-230 VAC, 60 Hz</b>			
	B2	0.10	70:1	24	30
	D2	0.12	60:1	28	30
	F2	0.19	40:1	43	30
	H2	0.25	30:1	57	20
	J2	0.30	20:1	86	17
		<b>3Ø, 1/4 BHP TEFC, 230-460 VAC, 60 Hz</b>			
		<b>3:1 Constant Torque Speed Range</b>			
	L2	0.10	70:1	24	30
	N2	0.12	60:1	28	30
	P2	0.19	40:1	43	30
	R2	0.25	30:1	57	20
	V2	0.30	20:1	86	17
	A	No Drive			

<sup>1</sup> Meets FDA and NSP for food handling. Maximum pressure: 13.5 psig.

## MODEL 2003 PUMP DATA

### Performance

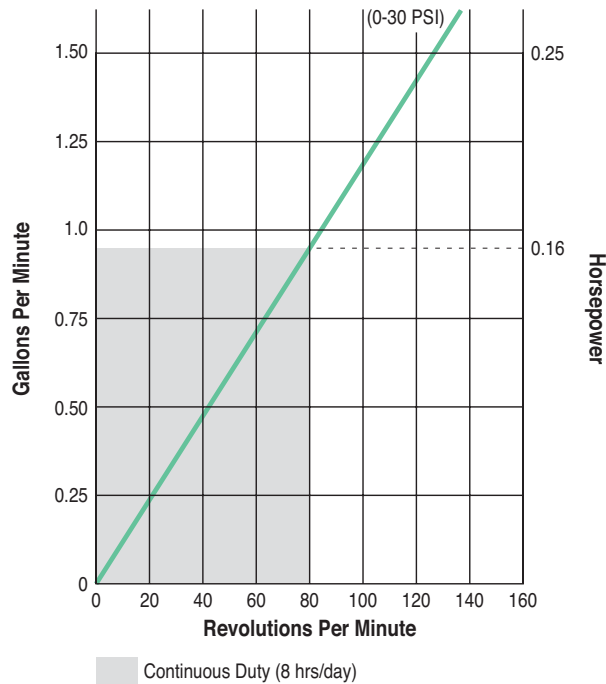

### Fluid Characteristics

Viscosity:	15,000 cps max.
Liquid Temperature:	180°F (82°C) max.
Solid Size:	(see page 4)
Fiber Length:	7/16 inch (11 mm) max.

### Specifications

Discharge Pressure:	30 psig (2 bar) max.
Suction Lift:	10 ft. (3 m)
Suction Pressure:	15 psig (1 bar) max.
Horsepower*:	1/4 max.
Hose Size:	13 x 22 x 390 mm
Displacement:	0.011 gal/rev
Weight (pump only):	10 lbs. (4.5 kg)
Weight (with drive):	19.8 lbs. (9 kg)

\* Pumps are shaft driven and require a gearbox and motor.  
See Ordering Information on following page for details.

### Materials of Construction

#### Non-wetted Parts

Casing: Aluminum Alloy  
Rotor: Aluminum Alloy  
Rollers: Plastic/Alloy

#### Wetted Parts

Hose:

EXTRUDED – Hypalon, Varpene, Silicone, PharMed®  
BRAIDED – Natural Rubber, EPDM

Inlet/Outlet Connections:

PTFE, Brass or Stainless Steel Hose Barb, Brass NPT, and  
Stainless Steel Sanitary Tri-clamp



## Dimensional Drawings

Inches (mm)

See Ordering Information for motor and gearbox sizes.

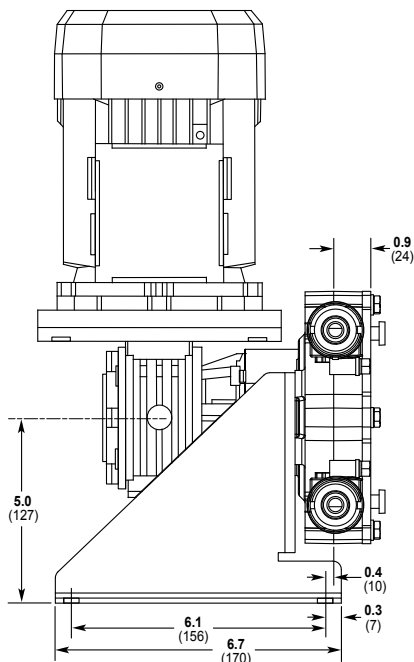
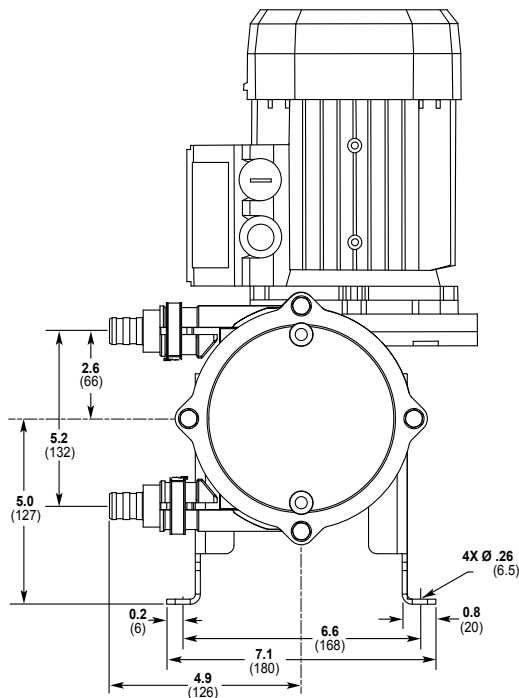

## Model 2003 Ordering Information

A complete Vector pump order number uses a 10-character order code to identify the desired hose, fittings and drive. Select the appropriate items from the chart below and use the order code from each group to complete the pump assembly order number.

<b>1</b>	<b>2</b>	<b>3</b>	<b>4</b>	<b>5</b>	<b>6</b>	<b>7</b>	<b>8</b>	<b>9</b>	<b>10</b>
2	0	0	3	-		-		-	

Order Digit	Order Code	Description			
<b>1-4</b>	<b>2003</b>	<b>Pump Designation</b> Model 2003 Shaft Drive Pump			
<b>5-6</b>		<b>Hose Material/Type</b>			
	FE	PharMed®, extruded <sup>(1)</sup>			
	HE	Hypalon, extruded			
	NF	Natural Rubber, fiber-braided			
	EF	EPDM, fiber-braided			
	SE	Silicone, extruded			
	VE	Varprenne, extruded			
<b>7-8</b>		<b>Connector Material/Style</b>			
	AA	PTFE, 3/4" hose barb			
	CC	316 SST, Sanitary, 3/4" tri-clamp			
	FF	Brass, 1/2" hose barb			
	GG	Brass, 1/2" male NPT			
	SS	316 SST, 1/2" hose barb			
	TT	316 SST, 3/4" male NPT			
<b>9-10</b>		<b>Drive</b>			
		<b>Flow GPM</b>			
		<b>Gear Ratio</b>			
		<b>Pump RPM</b>			
		<b>Max Psig</b>			
		<b>1Ø, 1/4 BHP TEFC, 115-230 VAC, 60 Hz</b>			
	B2	0.26	70:1	24	30
	D2	0.31	60:1	28	30
	F2	0.47	40:1	43	30
	H2	0.62	30:1	57	20
	J2	0.94	20:1	86	17
					<b>3Ø, 1/4 BHP TEFC, 230-460 VAC, 60 Hz</b>
					<b>3:1 Constant Torque Speed Range</b>
	L2	0.26	70:1	24	30
	N2	0.31	60:1	28	30
	P2	0.47	40:1	43	30
	R2	0.62	30:1	57	20
	V2	0.94	20:1	86	17
	A	No Drive			

<sup>1</sup> Meets FDA and NSP for food handling. Maximum pressure: 13.5 psig.

## MODEL 2004 PUMP DATA

### Performance

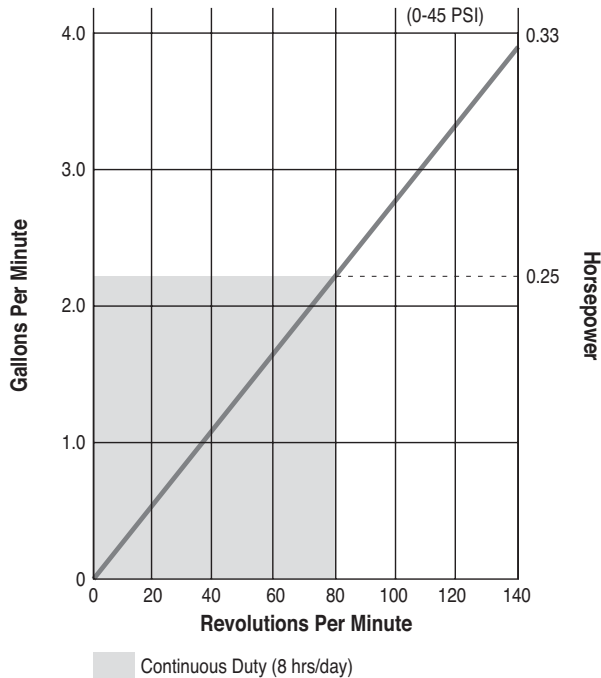

### Fluid Characteristics

Viscosity:	15,000 cps max.
Liquid Temperature:	180°F (82°C) max.
Solid Size:	(see page 4)
Fiber Length:	11/16 inch (17.4 mm) max.

### Specifications

Discharge Pressure:	45 psig (3 bar) max.
Suction Lift:	14 ft. (4.3 m)
Suction Pressure:	18 psig (1.2 bar) max.
Horsepower:*	1/3 max.
Hose Size:	17 x 31 x 590 mm
Displacement:	0.0286 gal/rev
Weight (pump only):	20 lbs. (9 kg)
Weight (with drive):	34 lbs. (15.5 kg)

\* Pumps are shaft driven and require a gearbox and motor.  
See Ordering Information on following page for details.

### Materials of Construction

#### Non-wetted Parts

Casing: Aluminum Alloy  
Rotor: Aluminum Alloy  
Rollers: Plastic/Alloy

#### Wetted Parts

Hose:

EXTRUDED – Neoprene, Hypalon, Varpren, Silicone  
BRAIDED – Natural Rubber, EPDM, Nitrile Rubber

Inlet/Outlet Connections:

PTFE or Stainless Steel Hose Barb, Stainless Steel or Carbon Steel ANSI Flange, Brass or Carbon Steel NPT, and Stainless Steel Sanitary Tri-clamp

## Dimensional Drawings

Inches (mm)

See Ordering Information for motor and gearbox sizes.

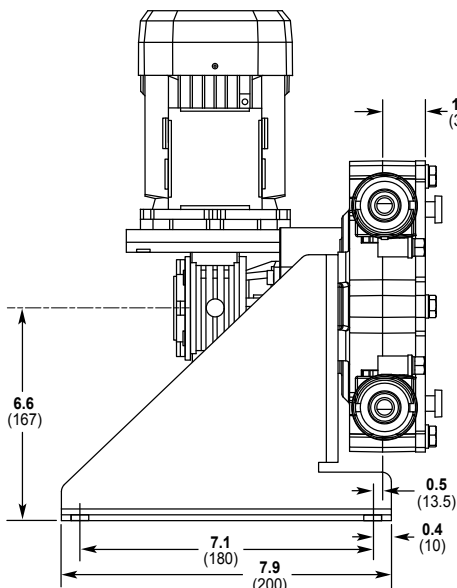
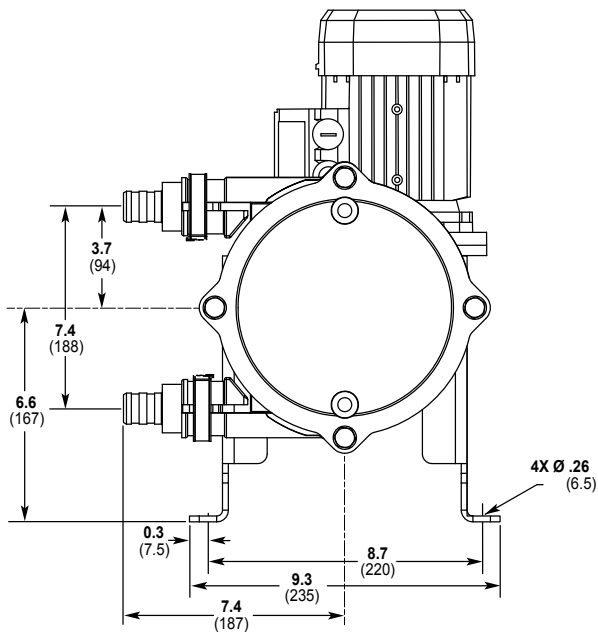

## Model 2004 Ordering Information

A complete Vector pump order number uses a 10-character order code to identify the desired hose, fittings and drive. Select the appropriate items from the chart below and use the order code from each group to complete the pump assembly order number.

<b>1</b>	<b>2</b>	<b>3</b>	<b>4</b>	<b>5</b>	<b>6</b>	<b>7</b>	<b>8</b>	<b>9</b>	<b>10</b>
2	0	0	4	-		-		-	

Order Digit	Order Code	Description
<b>1-4</b>	<b>2004</b>	<b>Pump Designation</b> Model 2004 Shaft Drive Pump
<b>5-6</b>		<b>Hose Material/Type</b>
	EF	EPDM, fiber-braided
	HE	Hypalon, extruded
	MF	Natural Rubber, fiber-braided, heavy-duty
	NF	Natural Rubber, fiber-braided
	PE	Neoprene, extruded
	SE	Silicone, extruded
	OF	Nitrile, Oil-rated, fiber-braided, heavy-duty
	VE	Varprene, extruded
<b>7-8</b>		<b>Connector Material/Style</b>
	AA	PTFE, 1" hose barb
	CC	316 SST, Sanitary, 1" tri-clamp
	EE	Carbon Steel, 3/4" male NPT
	FF	Brass, 3/4" hose barb
	GG	Brass, 3/4" male NPT
	SS	316 SST, 3/4" hose barb
	TT	316 SST, 3/4" male NPT
<b>9-10</b>		<b>Drive</b>
		<b>Flow Gear Pump Max</b>
		<b>GPM Ratio RPM Psig</b>
		<b>3Ø, 1/3 BHP TEFC, 230/460 VAC, 60 Hz</b>
		<b>10:1 Constant Torque Speed Range</b>
	<b>B2</b>	0.49 100:1 17.2 30(45) <sup>1</sup>
	<b>D2</b>	0.69 70:1 24 30(45) <sup>1</sup>
	<b>F2</b>	0.86 60:1 30 30(45) <sup>1</sup>
	<b>H2</b>	1.00 46:1 37.5 30(45) <sup>1</sup>
	<b>J2</b>	1.43 35:1 50 25(30) <sup>1</sup>
	<b>L2</b>	1.75 28:1 61 22(25) <sup>1</sup>
	<b>N2</b>	2.52 20:1 88 18(21)
	<b>A</b>	No Drive

<sup>1</sup>( ) Heavy-duty, fiber-braided hose

Note: 1Ø motors also available. Contact Wanner Engineering.

## MODEL 2005 PUMP DATA

### Performance

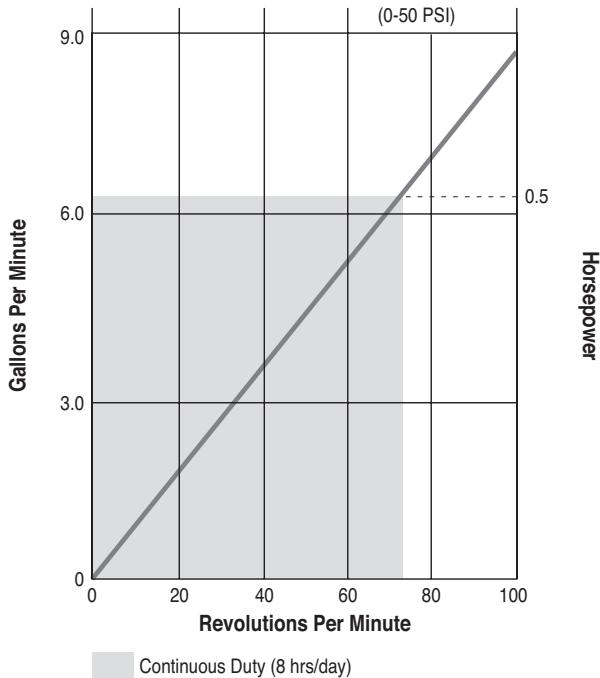

### Fluid Characteristics

Viscosity:	15,000 cps max.
Liquid Temperature:	180°F (82°C) max.
Solid Size:	(see page 4)
Fiber Length:	1-1/4 inch (31.7 mm) max.

### Specifications

Discharge Pressure:	50 psig (3.4 bar) max.
Suction Lift:	16.5 ft. (5 m)
Suction Pressure:	25 psig (1.7 bar) max.
Horsepower*:	3/4 max.
Hose Size:	25 x 43 x 860 mm
Displacement:	0.085 gal/rev (0.032 l/rev)
Weight (pump only):	40 lbs. (18 kg)
Weight (with drive):	83 lbs. (38 kg)

\* Pumps are shaft driven and require a gearbox and motor. See Ordering Information on following page for details.

### Materials of Construction

#### Non-wetted Parts

Casing: Aluminum Alloy  
 Rotor: Aluminum Alloy  
 Rollers: Aluminum Alloy

#### Wetted Parts

Hose:  
 EXTRUDED – Neoprene, Varpene  
 BRAIDED – EPDM, Hypalon, Nitrile Rubber, Natural Rubber (regular and heavy-duty)

#### Inlet/Outlet Connections:

PTFE or Stainless Steel Hose Barb, Stainless Steel or Carbon Steel ANSI Flange, PTFE NPT, and Stainless Steel Sanitary Tri-clamp

## Dimensional Drawings

Inches (mm)

See Ordering Information for motor and gearbox sizes.

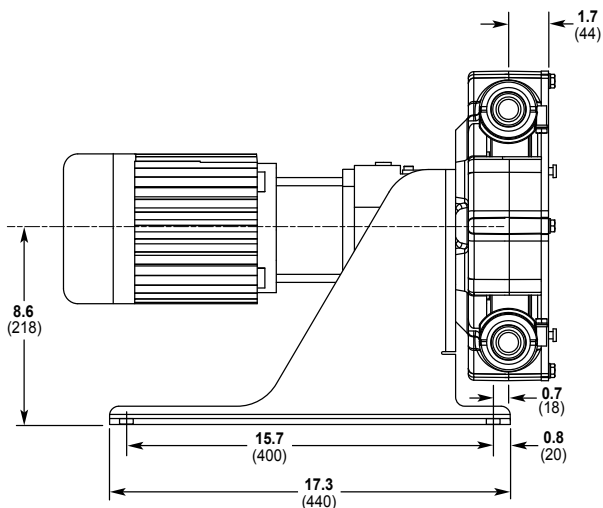
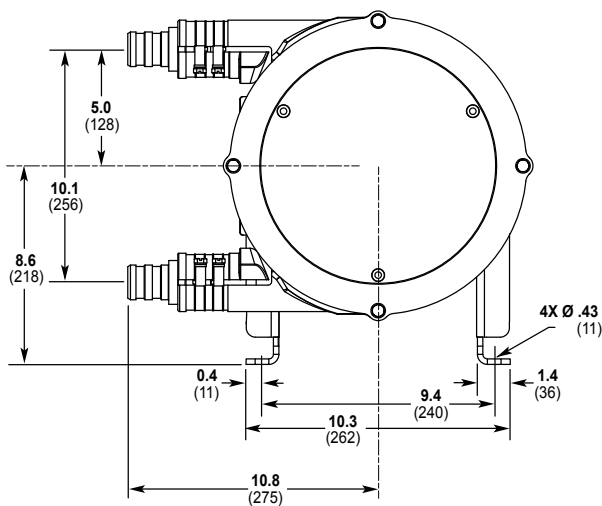

## Model 2005 Ordering Information

A complete Vector pump order number uses a 10-character order code to identify the desired hose, fittings and drive. Select the appropriate items from the chart below and use the order code from each group to complete the pump assembly order number.

<b>1</b>	<b>2</b>	<b>3</b>	<b>4</b>	<b>5</b>	<b>6</b>	<b>7</b>	<b>8</b>	<b>9</b>	<b>10</b>
2	0	0	5	-		-		-	

Order Digit	Order Code	Description
<b>1-4</b>	<b>2005</b>	<b>Pump Designation</b> Model 2005 Shaft Drive Pump
<b>5-6</b>		<b>Hose Material/Type</b>
	EF	EPDM, fiber-braided
	HF	Hypalon, fiber-braided
	MF	Natural Rubber, fiber-braided, heavy-duty (50 psig max.)
	NF	Natural Rubber, fiber-braided
	OF	Nitrile, Oil-rated, fiber-braided, heavy-duty (50 psig max.)
	PE	Neoprene, extruded (30 psig max.)
	VE	Varprene, extruded (30 psig max.)
<b>7-8</b>		<b>Connector Material/Style</b>
	AA	PTFE, 1-1/4" hose barb
	BB	316 SST, 1" ANSI flange
	CC	316 SST, Sanitary, 1-1/2" tri-clamp
	EE	Carbon Steel, 1" male NPT
	HH	PTFE, 1" male NPT
	SS	316 SST, 1" hose barb
<b>9-10</b>		<b>Drive</b>
		<b>Flow Gear Pump Max</b>
		<b>GPM Ratio RPM Psig</b>
		<b>3Ø, 1/2 BHP TEFC, 230-460 VAC, 60 Hz</b>
		<b>4:1 Constant Torque Speed Range</b>
	B2	1.7 85:1 20 37(50) <sup>1</sup>
	D2	2.5 56:1 30 37(50) <sup>1</sup>
	F2	3.2 45:1 38 37(45) <sup>1</sup>
	H2	3.8 37:1 46 37(43) <sup>1</sup>
		<b>3Ø, 3/4 BHP TEFC, 230-460 VAC, 60 Hz</b>
		<b>4:1 Constant Torque Speed Range</b>
	J2	5.9 24:1 70 29(32) <sup>1</sup>
	A	No Drive

<sup>1</sup>( ) Heavy-duty, fiber-braided hose

## MODEL 3005 PUMP DATA

### Performance

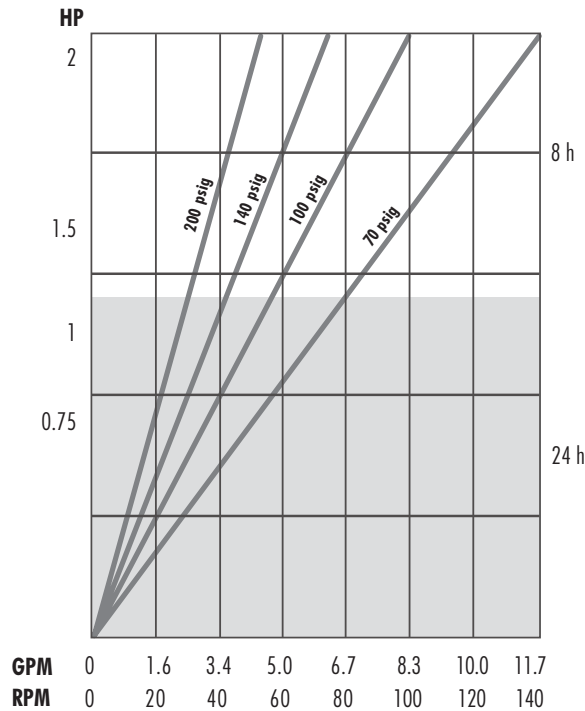

### Fluid Characteristics

Viscosity:	100,000 cps max.
Liquid Temperature:	180°F (82°C) max.
Solid Size:	(see page 4)
Fiber Length:	4 inch (100 mm) max.

### Specifications

Discharge Pressure:	200 psig (13.8 bar) max.
Suction Lift:	22 ft. (6.7 m)
Suction Pressure:	21 psig (1.4 bar) max.
Horsepower:*	2 max.
Hose Size:	25 x 44 x 850 mm
Displacement:	0.079 gal/rev (0.30 l/rev)
Lubrication Fluid:	1.6 quarts max.
Weight (pump only):	77 lbs. (35 kg)
Weight (with drive):	176 lbs. (80 kg)

\* Pumps are shaft driven and require a gearbox and motor.  
See Ordering Information on following page for details.

### Materials of Construction

#### Non-wetted Parts

- Casing: Aluminum
- Rotor: Cast Iron
- Rollers: Steel
- Roller Holders: Cast Iron
- Frame: Steel

#### Wetted Parts

- Hose: FIBER BRAIDED – EPDM, Hypalon, Nitrile Rubber, Natural Rubber
- Inlet/Outlet Connections: PVC, Carbon Steel, and Stainless Steel

## Dimensional Drawings

Inches (mm)

See Ordering Information for motor and gearbox sizes.

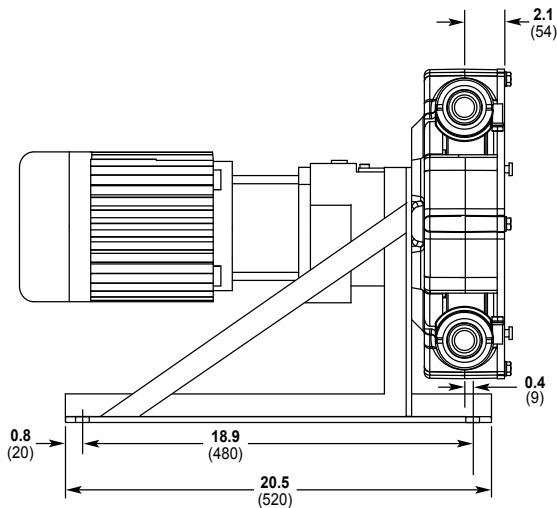
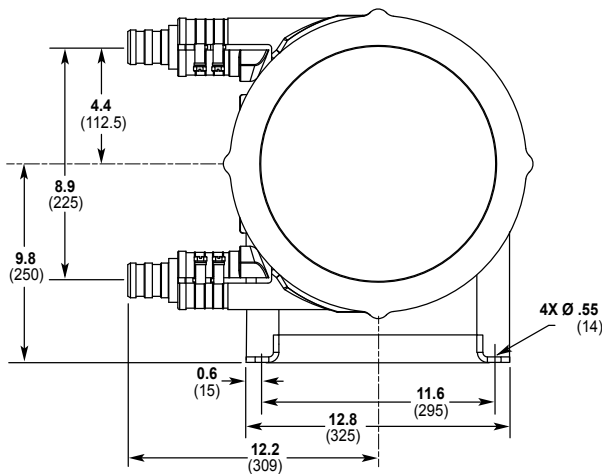

## Model 3005 Ordering Information

A complete Vector pump order number uses a 10-character order code to identify the desired hose, fittings and drive. Select the appropriate items from the chart below and use the order code from each group to complete the pump assembly order number.

<b>1</b>	<b>2</b>	<b>3</b>	<b>4</b>	<b>5</b>	<b>6</b>	<b>7</b>	<b>8</b>	<b>9</b>	<b>10</b>
3	0	0	5	-		-		-	

Order Digit	Order Code	Description		
<b>1-4 Pump Designation</b>				
<b>1-4</b>	<b>3005</b>	Model 3005 Shaft Drive Pump		
<b>5-6 Hose Material/Type</b>				
	<b>EF</b>	EPDM, fiber-braided (100 psig max.)		
	<b>HF</b>	Hypalon, fiber-braided (100 psig max.)		
	<b>MF</b>	Natural Rubber, fiber-braided, heavy-duty (200 psig max.)		
	<b>NF</b>	Natural Rubber, fiber-braided (100 psig max.)		
	<b>OF</b>	Nitrile, Oil-rated, fiber-braided, heavy-duty (200 psig max.)		
<b>7-8 Connector Material/Style</b>				
	<b>EB</b>	Carbon Steel, 1-1/4" hose barb		
	<b>EE</b>	Carbon Steel, 1-1/4" male NPT		
	<b>PV</b>	PVC, 1-1/4" hose barb		
	<b>TT</b>	316 SST, 1-1/4" MNPT		
	<b>SS</b>	316 SST, 1-1/4" hose barb		
<b>9-10 Drive</b>				
	<b>Flow GPM</b>	<b>Gear Ratio</b>	<b>Pump RPM</b>	<b>Max Psig</b>
<b>3Ø, 3/4 BHP TEFC, 230-460 VAC, 60 Hz</b>				
<b>4:1 Constant Torque Speed Range</b>				
<b>B2</b>	1.3	90:1	19	200 <sup>(1)</sup>
<b>D2</b>	1.7	69:1	25	175 <sup>(1)</sup>
<b>3Ø, 1 BHP TEFC, 230-460 VAC, 60 Hz</b>				
<b>4:1 Constant Torque Speed Range</b>				
<b>F2</b>	2.8	43:1	39	150 <sup>(1)</sup>
<b>3Ø, 2 BHP TEFC, 230-460 VAC, 60 Hz</b>				
<b>4:1 Constant Torque Speed Range</b>				
<b>H2</b>	5.7	22:1	78	100 <sup>(1)</sup>
<b>J2</b>	7.6	17:1	102	75 <sup>(1)</sup>
<b>L2</b>	9.2	14:1	123	50 <sup>(1)</sup>
<b>A</b>	No Drive			
		<sup>(1)</sup> ( ) Fluid Viscosity	Pressure Range	
		0-250 cps	0-75 psig	
		250-100,000 cps	0-200 psig	

## MODEL 2006 PUMP DATA

### Performance

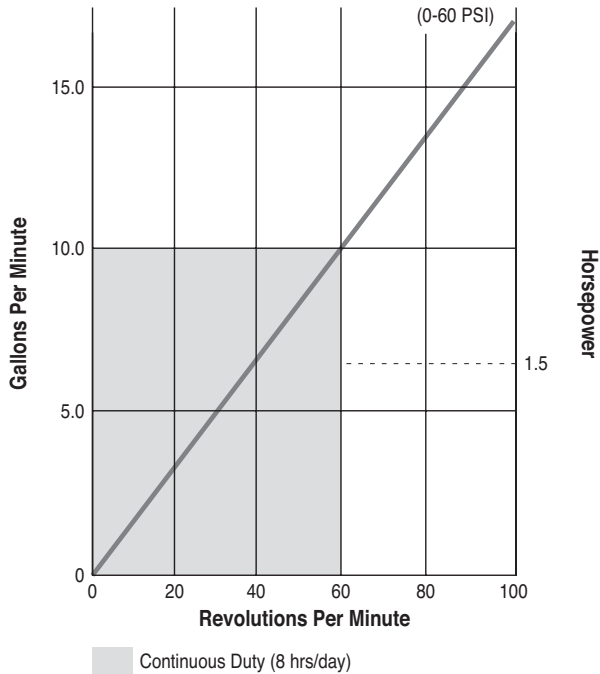

### Fluid Characteristics

Viscosity:	15,000 cps max.
Liquid Temperature:	180°F (82°C) max.
Solid Size:	(see page 4)
Fiber Length:	1-7/8 inch (47.6 mm) max.

### Specifications

Discharge Pressure:	60 psig (4.1 bar) max.
Suction Lift:	24 ft. (7.3 m)
Suction Pressure:	25 psig (1.7 bar) max.
Horsepower:*	2 max.
Hose Size:	30 x 55 x 1150 mm
Displacement:	0.182 gal/rev
Weight (pump only):	95 lbs. (43 kg)
Weight (with drive):	171 lbs. (78 kg)

\* Pumps are shaft driven and require a gearbox and motor. See Ordering Information on following page for details.

### Materials of Construction

#### Non-wetted Parts

Casing: Aluminum Alloy  
 Rotor: Aluminum Alloy  
 Rollers: Aluminum Alloy

#### Wetted Parts

Hose:

EXTRUDED – Neoprene, Varpene, Silicone  
 BRAIDED – EPDM, Hypalon, Nitrile Rubber, Natural Rubber (regular and heavy-duty)

Inlet/Outlet Connections:

PTFE or Stainless Steel Hose Barb, Stainless Steel or Carbon Steel ANSI Flange, PTFE NPT, and Stainless Steel Sanitary Tri-clamp



## Dimensional Drawings

Inches (mm)

See Ordering Information for motor and gearbox sizes.

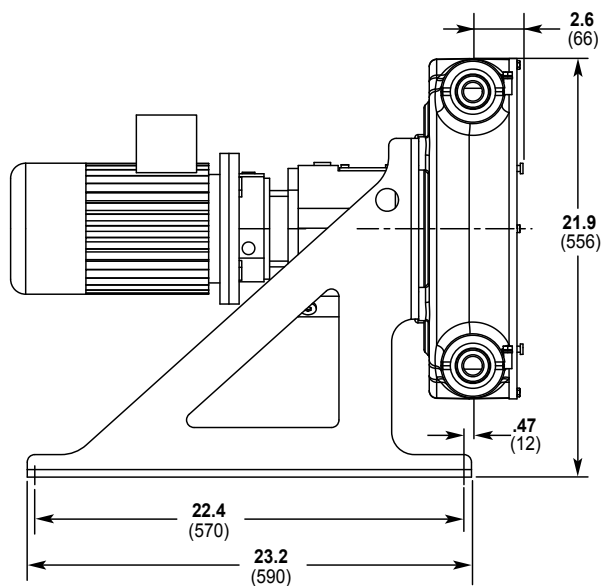
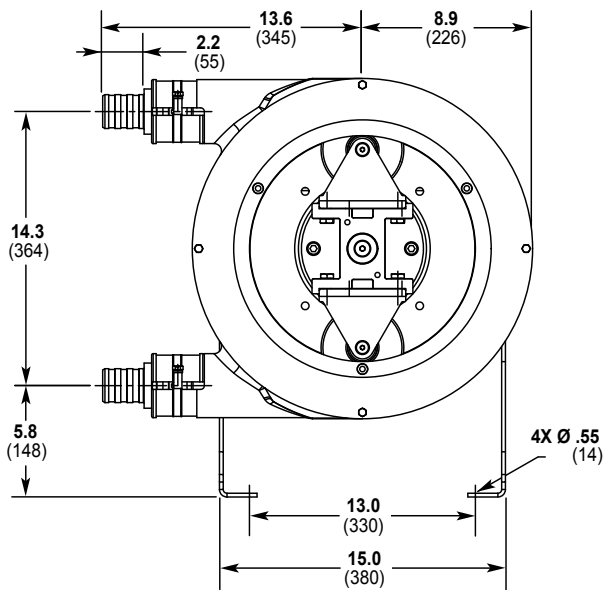

## Model 2006 Ordering Information

A complete Vector pump order number uses a 10-character order code to identify the desired hose, fittings and drive. Select the appropriate items from the chart below and use the order code from each group to complete the pump assembly order number.

<b>1</b>	<b>2</b>	<b>3</b>	<b>4</b>	<b>5</b>	<b>6</b>	<b>7</b>	<b>8</b>	<b>9</b>	<b>10</b>
2	0	0	6						

Order Digit	Order Code	Description		
<b>1-4 Pump Designation</b>				
	2006	Model 2006 Shaft Drive Pump		
<b>5-6 Hose Material/Type</b>				
	EF	EPDM, fiber-braided		
	HF	Hypalon, fiber-braided		
	MF	Natural Rubber, fiber-braided, heavy-duty (60 psig max.)		
	NF	Natural Rubber, fiber-braided		
	PE	Neoprene, extruded (30 psig max.)		
	SE	Silicone, extruded (30 psig max.)		
	OF	Nitrile, Oil-rated, fiber-braided, heavy-duty (60 psig max.)		
	VE	Varprene, extruded (30 psig max.)		
<b>7-8 Connector Material/Style</b>				
	AA	PTFE, 1-1/4" hose barb		
	BB	316 SST, 1-1/4" ANSI flange		
	CC	316 SST, Sanitary, 1-1/2" tri-clamp		
	DD	Carbon Steel, 1-1/4" ANSI flange		
	EE	Carbon Steel, 1-1/2" male NPT		
	HH	PTFE, 1-1/4" male NPT		
	TT	SST 1-1/2" NPT		
	SS	316 SST, 1-1/4" hose barb		
<b>9-10 Drive</b>				
	<b>Flow GPM</b>	<b>Gear Ratio</b>	<b>Pump RPM</b>	<b>Max Psig</b>
<b>3Ø, 1 BHP TEFC, 230-460 VAC, 60 Hz</b>				
<b>4:1 Constant Torque Speed Range</b>				
B2	3.5	90:1	19	45(60) <sup>1</sup>
<b>3Ø, 1-1/2 BHP TEFC, 230-460 VAC, 60 Hz</b>				
<b>4:1 Constant Torque Speed Range</b>				
D2	4.8	65:1	27	45(60) <sup>1</sup>
F2	7.2	43:1	40	45(60) <sup>1</sup>
<b>3Ø, 2 BHP TEFC, 230-460 VAC, 60 Hz</b>				
<b>4:1 Constant Torque Speed Range</b>				
H2	10.3	30:1	57	35(45) <sup>1</sup>
J2	14.1	22:1	78	35(45) <sup>1</sup>
A	No Drive			

<sup>1</sup>( ) Heavy-duty, fiber-braided hose

## MODEL 2007 PUMP DATA

### Performance

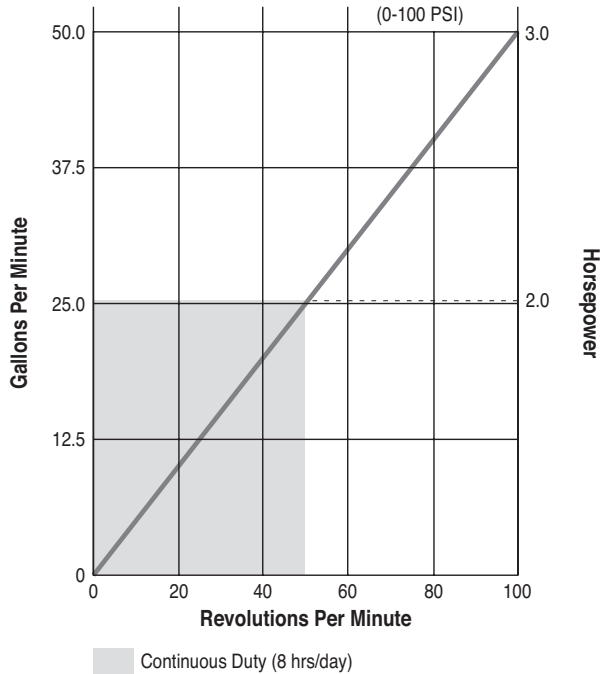

### Fluid Characteristics

Viscosity:	15,000 cps max.
Liquid Temperature:	180°F (82°C) max.
Solid Size:	(see page 4)
Fiber Length:	2-3/8 inch (60 mm) max.

### Specifications

Discharge Pressure:	100 psig (7 bar) max.
Suction Lift:	24 ft. (7.3 m)
Suction Pressure:	25 psig (1.7 bar) max.
Horsepower:*	3 max.
Hose Size:	45 x 75 x 1455 mm
Displacement:	0.51 gal/rev
Weight (pump only):	185 lbs. (84 kg)
Weight (with drive):	275 lbs. (125 kg)

\* Pumps are shaft driven and require a gearbox and motor. See Ordering Information on following page for details.

### Materials of Construction

#### Non-wetted Parts

Casing: Aluminum Alloy  
Rotor: Aluminum Alloy  
Rollers: Aluminum Alloy

#### Wetted Parts

Hose:  
EXTRUDED – Varprene  
BRAIDED – EPDM, Hypalon, Nitrile Rubber, Natural Rubber (regular and heavy-duty)

#### Inlet/Outlet Connections:

PTFE or Stainless Steel Hose Barb, Stainless Steel or Carbon Steel ANSI Flange, PTFE NPT, and Stainless Steel Sanitary Tri-clamp

## Dimensional Drawings

Inches (mm)

See Ordering Information for motor and gearbox sizes.

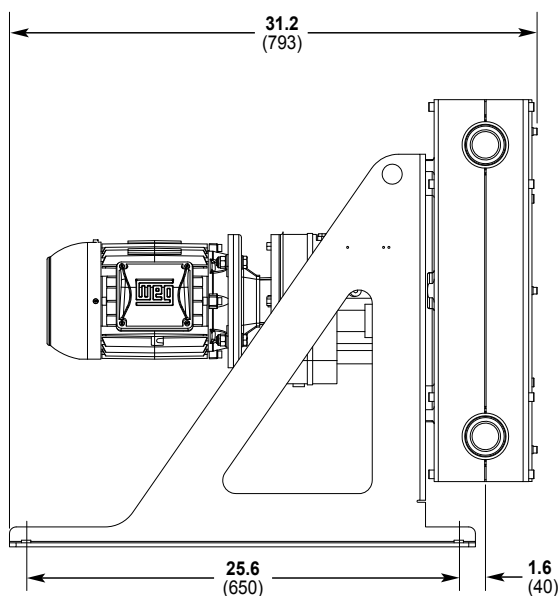
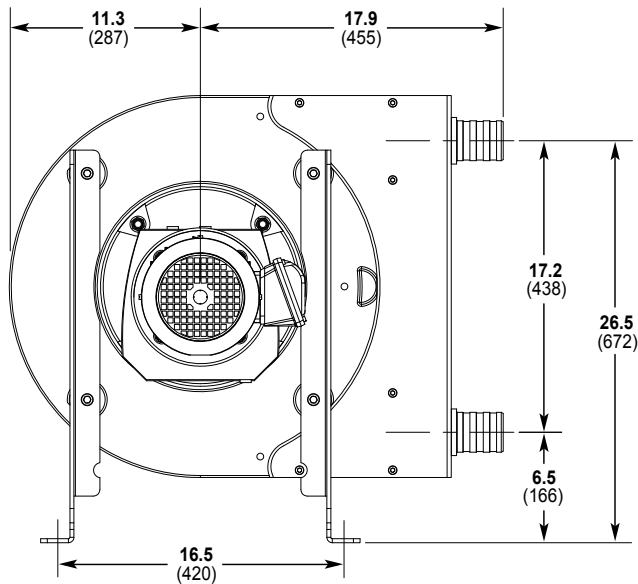

## Model 2007 Ordering Information

A complete Vector pump order number uses a 10-character order code to identify the desired hose, fittings and drive. Select the appropriate items from the chart below and use the order code from each group to complete the pump assembly order number.

<b>1</b>	<b>2</b>	<b>3</b>	<b>4</b>	<b>5</b>	<b>6</b>	<b>7</b>	<b>8</b>	<b>9</b>	<b>10</b>
2	0	0	7						

Order Digit	Order Code	Description	
<b>1-4</b>	<b>2007</b>	<b>Pump Designation</b> Model 2007 Shaft Drive Pump	
<b>5-6</b>		<b>Hose Material/Type</b>	
	EF	EPDM, fiber-braided	
	HF	Hypalon, fiber-braided	
	MF	Natural Rubber, fiber-braided, heavy-duty (100 psig max.)	
	NF	Natural Rubber, fiber-braided	
	OF	Nitrile, Oil-rated, fiber-braided, heavy-duty (100 psig max.)	
	VE	Varprene, extruded (30 psig max.)	
<b>7-8</b>		<b>Connector Material/Style</b>	
	AA	PTFE, 2" hose barb (60 psig max.)	
	BB	316 SST, 2" ANSI flange	
	CC	316 SST, Sanitary, 2" tri-clamp	
	DD	Carbon Steel, 2" ANSI flange	
	EE	Carbon Steel, 2" male NPT	
	HH	PTFE, 2" male NPT (60 psig max.)	
	SS	316 SST, 2.5" hose barb	
<b>9-10</b>		<b>Drive</b>	
		<b>Flow GPM</b>	
		<b>Gear Ratio</b>	
		<b>Pump RPM</b>	
		<b>Max Psig</b>	
		<b>3Ø, 1-1/2 BHP TEFC, 230-460 VAC, 60 Hz</b>	
		<b>4:1 Constant Torque Speed Range</b>	
	B2	7.1	121:1
	D2	10.5	82:1
		<b>3Ø, 2 BHP TEFC, 230-460 VAC, 60 Hz</b>	
		<b>4:1 Constant Torque Speed Range</b>	
	F2	15.3	58:1
	H2	20.4	43:1
	J2	25.8	33:1
		<b>3Ø, 3 BHP TEFC, 230-460 VAC, 60 Hz</b>	
		<b>3:1 Constant Torque Speed Range</b>	
	L2	40.5	21:1
	A	No Drive	

<sup>1</sup>( ) Heavy-duty, fiber-braided hose

## MODEL 2008 PUMP DATA

### Performance

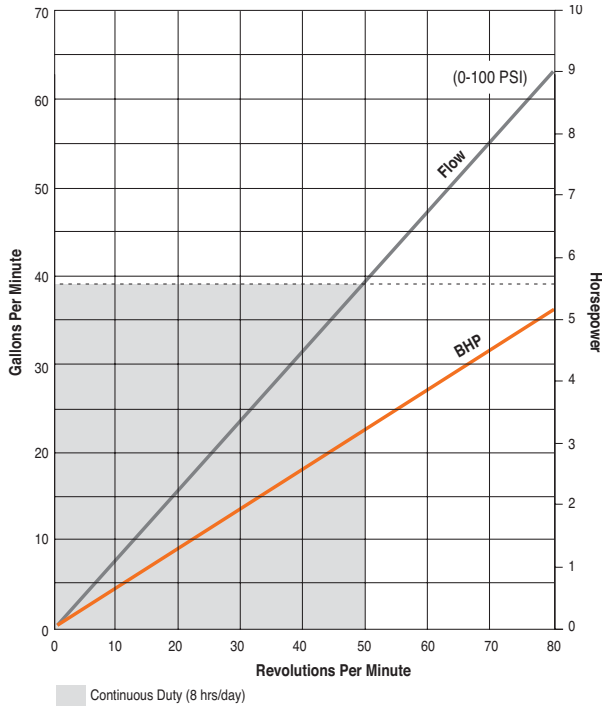

### Fluid Characteristics

Viscosity:	100,000 cps max.
Liquid Temperature:	180°F (82°C) max.
Solid Size:	(see page 4)
Fiber Length:	36 inch (914 mm) max.

### Specifications

Discharge Pressure:	100 psig (7 bar) max.
Suction Lift:	24 ft. (7.3 m)
Suction Pressure:	21 psig (1.4 bar) max.
Horsepower:*	12 max.
Hose Size:	55 x 90 x 1850 mm
Displacement:	1.05 gal/rev
Lubrication Fluid:	4 gal max.
Weight (pump only):	529 lbs. (240 kg)
Weight (with drive):	739 lbs. (336 kg)

\* Pumps are shaft driven and require a gearbox and motor. See Ordering Information on following page for details.

### Materials of Construction

#### Non-wetted Parts

Casing: Aluminum Alloy  
 Rotor: Aluminum Alloy  
 Rollers: Steel

#### Wetted Parts

Hose:

BRAIDED – Hypalon, EPDM, Natural Rubber (regular and heavy-duty), Oil-rated Nitrile

Inlet/Outlet Connections:

Stainless Steel Flange, Carbon Steel NPT, Stainless Steel NPT, Nylon NPT, Polypropylene NPT

## Dimensional Drawings

Inches (mm)

See Ordering Information for motor and gearbox sizes.

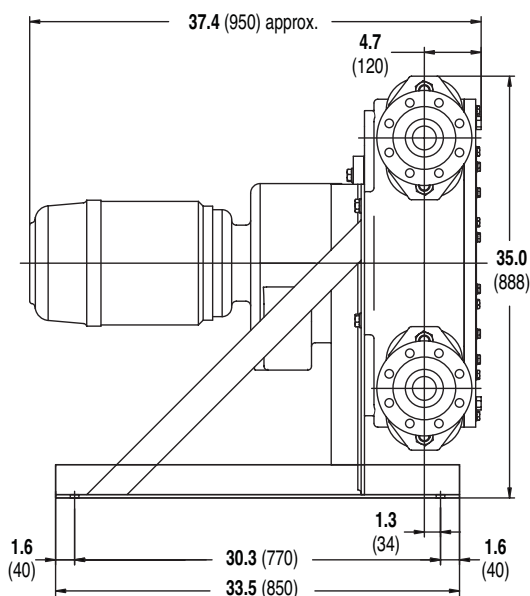
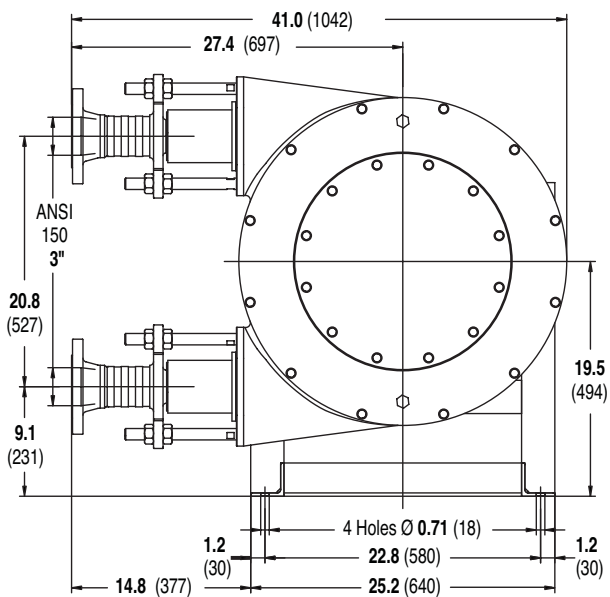

## Model 2008 Ordering Information

A complete Vector pump order number uses a 10-character order code to identify the desired hose, fittings and drive. Select the appropriate items from the chart below and use the order code from each group to complete the pump assembly order number.

1	2	3	4	5	6	7	8	9	10
2	0	0	8						

Order Digit	Order Code	Description
-------------	------------	-------------

<b>1-4</b>	<b>Pump Designation</b>
2008	Model 2008 Shaft Drive Pump

<b>5-6</b>	<b>Hose Material/Type</b>
EF	EPDM, fiber-braided (75 psig max.)
HF	Hypalon, fiber-braided (75 psig max.)
MF	Natural Rubber, fiber-braided, heavy-duty (100 psig max.)
NF	Natural Rubber, fiber-braided (75 psig max.)
OF	Oil-rated Nitrile, fiber-braided, heavy-duty (100 psig max.)

<b>7-8</b>	<b>Connector Material/Style</b>
BB	316 SST, 3" ANSI flange
EE	Carbon Steel, 3" male NPT
NN	Nylon, 3" male NPT (200°F max.)
PP	Polypropylene, 3" male NPT (185°F max.)
TT	316 SST, 3" male NPT

<b>9-10</b>	<b>Drive</b>				
	<b>Flow GPM</b>				
	<b>Gear Ratio</b>				
	<b>Pump RPM</b>				
	<b>Max Psig</b>				
	<b>BHP</b>				
	<b>3Ø, TEFC, 230-460 VAC, 60 Hz</b>				
	<b>4:1 Constant Torque Speed Range</b>				
B2	16	83:1	21	100 <sup>(1)</sup>	5
D2	23	60:1	29	100 <sup>(1)</sup>	5
F2	28	48:1	36	100 <sup>(1)</sup>	5
H2	31	42:1	40	100 <sup>(1)</sup>	5
J2	36	37:1	47	100 <sup>(1)</sup>	5
L2	50	27:1	64	90 <sup>(1)</sup>	7.5
A	No Drive				

<sup>1</sup>( ) Fluid Viscosity Pressure Range  
 0-250 cps 0-75 psig  
 250-100,000 cps 0-100 psig

## MODEL 2009 PUMP DATA

### Performance

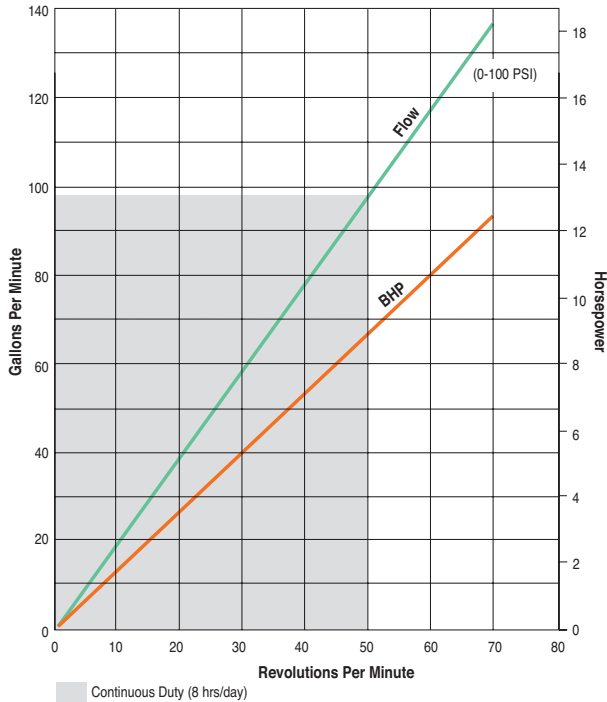

### Fluid Characteristics

Viscosity:	100,000 cps max.
Liquid Temperature:	180°F (82°C) max.
Solid Size:	(see page 4)
Fiber Length:	36 inch (914 mm) max.

### Specifications

Discharge Pressure:	100 psig (7 bar) max.
Suction Lift:	24 ft. (7.3 m)
Suction Pressure:	21 psig (1.4 bar) max.
Horsepower:*	18 max.
Hose Size:	75 x 120 x 2400 mm
Displacement:	2.5 gal/rev
Lubrication Fluid:	8.5 gal max.
Weight (pump only):	881 lbs. (400 kg)
Weight (with drive):	1,213 lbs. (551 kg)

\* Pumps are shaft driven and require a gearbox and motor.  
See Ordering Information on following page for details.

### Materials of Construction

#### Non-wetted Parts

Casing: Aluminum Alloy  
Rotor: Aluminum Alloy  
Rollers: Steel

#### Wetted Parts

Hose:

BRAIDED – Hypalon, EPDM, Natural Rubber (regular and heavy-duty), Oil-rated Nitrile

Inlet/Outlet Connections:

Stainless Steel Flange, Stainless Steel NPT, Carbon Steel NPT, Nylon NPT

## Dimensional Drawings

Inches (mm)

See Ordering Information for motor and gearbox sizes.

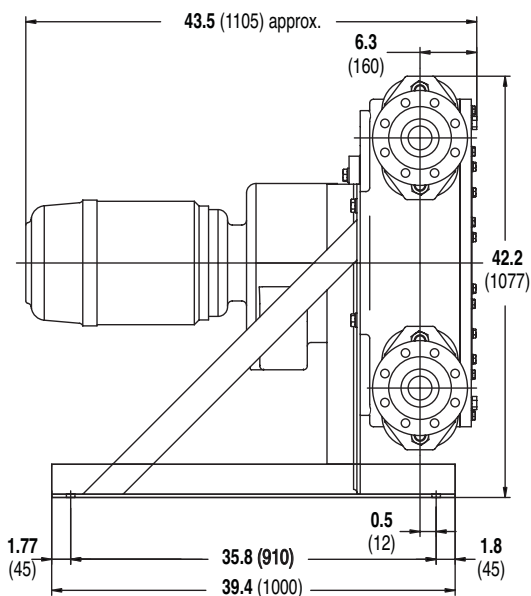
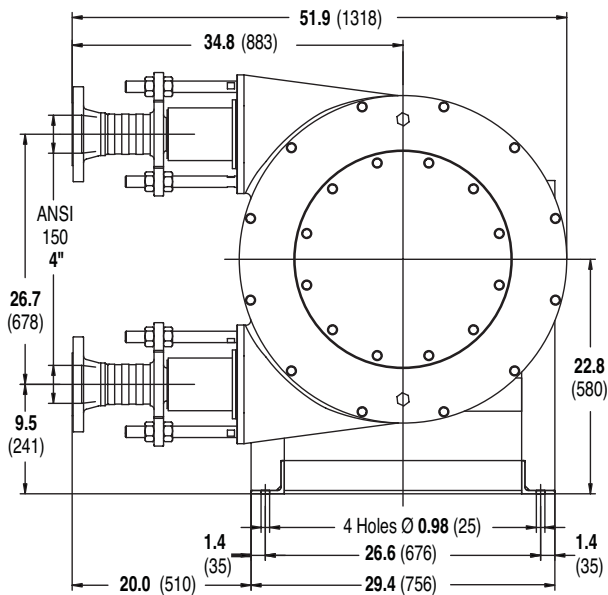

## Model 2009 Ordering Information

A complete Vector pump order number uses a 10-character order code to identify the desired hose, fittings and drive. Select the appropriate items from the chart below and use the order code from each group to complete the pump assembly order number.

<b>1</b>	<b>2</b>	<b>3</b>	<b>4</b>	<b>5</b>	<b>6</b>	<b>7</b>	<b>8</b>	<b>9</b>	<b>10</b>
2	0	0	9						

Order Digit	Order Code	Description
-------------	------------	-------------

<b>1-4</b>	<b>Pump Designation</b>
2009	Model 2009 Shaft Drive Pump

<b>5-6</b>	<b>Hose Material/Type</b>
EF	EPDM, fiber-braided (75 psig max.)
HF	Hypalon, fiber-braided (75 psig max.)
MF	Natural Rubber, fiber-braided, heavy-duty (100 psig max.)
NF	Natural Rubber, fiber-braided (75 psig max.)
OF	Oil-rated Nitrile, fiber-braided, heavy-duty (100 psig max.)

<b>7-8</b>	<b>Connector Material/Style</b>
BB	316 SST, 4" ANSI flange
EE	Carbon Steel, 4" male NPT
NN	Nylon, 4" male NPT (200° F max)
TT	316 SST, 4" male NPT

<b>9-10</b>	<b>Drive</b>				
	<b>Flow GPM</b>				
	<b>Gear Ratio</b>				
	<b>Pump RPM</b>				
	<b>Max Psig</b>				
	<b>BHP</b>				
	<b>3Ø, TEFC, 230-460 VAC, 60 Hz</b>				
	<b>4:1 Constant Torque Speed Range</b>				
B2	41	79:1	21	100 <sup>(1)</sup>	7.5
D2	57	60:1	29	100 <sup>(1)</sup>	7.5
F2	73	48:1	37	100 <sup>(1)</sup>	7.5
H2	84	41:1	43	100 <sup>(1)</sup>	10
J2	97	35:1	49	100 <sup>(1)</sup>	10
L2	120	28:1	63	90 <sup>(1)</sup>	15
A	No Drive				

<sup>1</sup>( ) Fluid Viscosity Pressure Range  
 0-250 cps 0-75 psig  
 250-100,000 cps 0-100 psig

## MODEL 2010 PUMP DATA

### Performance

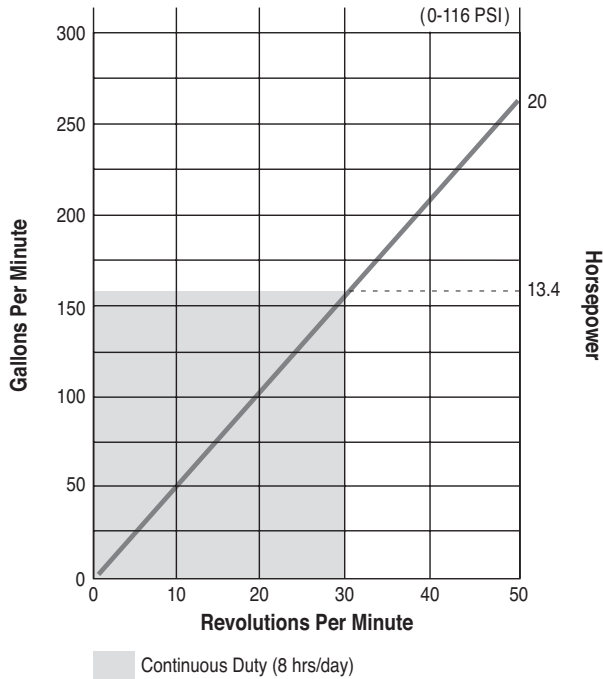

### Fluid Characteristics

Viscosity:	100,000 cps max.
Liquid Temperature:	180°F (82°C) max.
Solid Size:	(see page 4)
Fiber Length:	36 inch (914 mm) max.

### Specifications

Discharge Pressure:	116 psig (8 bar) max.
Suction Lift:	22 ft. (7.3 m)
Suction Pressure:	21 psig (1.4 bar) max.
Horsepower:*	20 max.
Hose Size:	100 x 144 x 3250 mm
Displacement:	5.28 gal/rev
Lubrication Fluid:	15.85 gal max.
Weight (pump only):	1,984 lbs. (900 kg)
Weight (with drive):	2,535 lbs. (1,152 kg)

\* Pumps are shaft driven and require a gearbox and motor. See Ordering Information on following page for details.

### Materials of Construction

#### Non-wetted Parts

Casing & Front Cover: Cast Iron  
 Rotor Assembly: Aluminum  
 Rollers: Aluminum

#### Wetted Parts

Hose:  
 FIBER BRAIDED – EPDM, Hypalon, Nitrile Rubber, Natural Rubber (regular and heavy-duty)

Inlet/Outlet Connections:  
 Carbon Steel ANSI Flange, Nylon & PVC NPT



## Dimensional Drawings

Inches (mm)

See Ordering Information for motor and gearbox sizes.

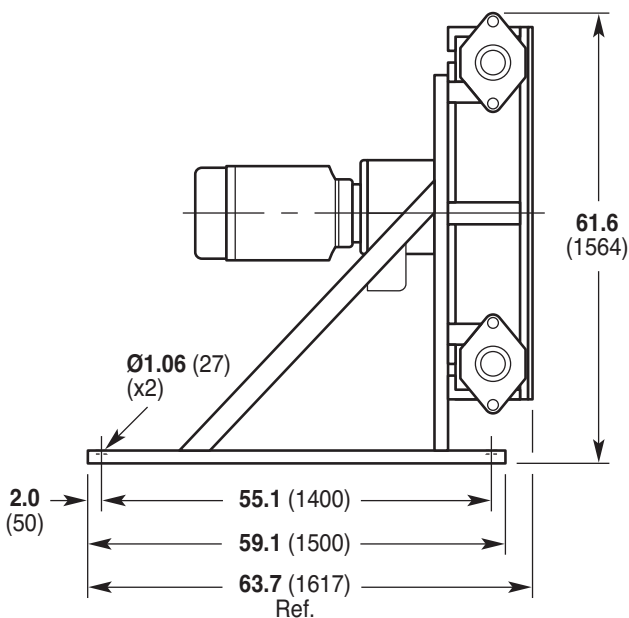
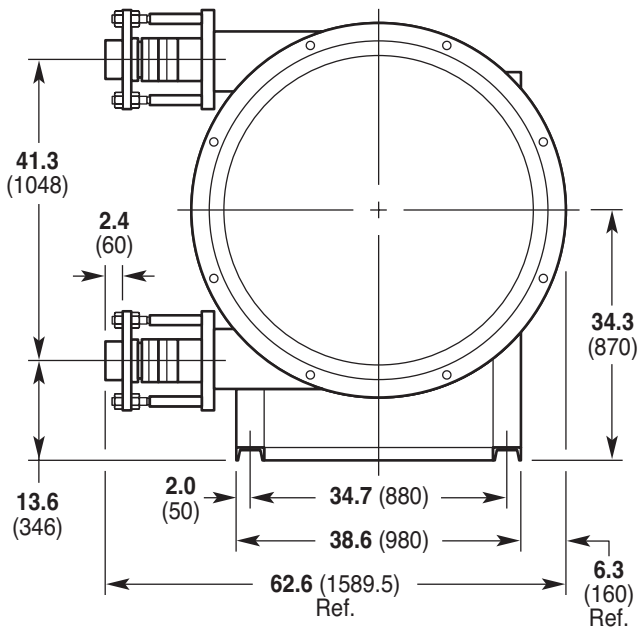

## Model 2010 Ordering Information

A complete Vector pump order number uses a 10-character order code to identify the desired hose, fittings and drive. Select the appropriate items from the chart below and use the order code from each group to complete the pump assembly order number.

<b>1</b>	<b>2</b>	<b>3</b>	<b>4</b>	<b>5</b>	<b>6</b>	<b>7</b>	<b>8</b>	<b>9</b>	<b>10</b>
2	0	1	0						

Order Digit	Order Code	Description
-------------	------------	-------------

<b>1-4</b>	<b>Pump Designation</b>	
	<b>2010</b>	Model 2010 Shaft Drive Pump

<b>5-6</b>	<b>Hose Material/Type</b>	
	<b>BS</b>	Oil-rated Nitrile, fiber-braided
	<b>EF</b>	EPDM, fiber-braided
	<b>HS</b>	Hypalon, fiber-braided (70 psig max.)
	<b>MS</b>	Natural Rubber, fiber-braided

<b>7-8</b>	<b>Connector Material/Style</b>	
	<b>DD</b>	Carbon Steel, 6" ANSI flange
	<b>NN</b>	Nylon, 5" ANSI flange (200°F/93.3°C max.)
	<b>PP</b>	PVC, 5" ANSI flange (176°F/80°C max.)

<b>9-10</b>	<b>Drive</b>			
	<b>Flow GPM</b>	<b>Gear Ratio</b>	<b>Pump RPM</b>	<b>Max Psig</b>
	<b>3Ø, 10 BHP TEFC, 230-460 VAC, 60 Hz</b>			
	<b>4:1 Constant Torque Speed Range</b>			
<b>B2</b>	52	174:1	10	116 <sup>(1)</sup>
<b>F2</b>	79	114:1	15	116 <sup>(1)</sup>
	<b>3Ø, 15 BHP TEFC, 230-460 VAC, 60 Hz</b>			
	<b>4:1 Constant Torque Speed Range</b>			
<b>G2</b>	104	89:1	20	116 <sup>(1)</sup>
<b>M2</b>	153	59:1	29	116 <sup>(1)</sup>
	<b>3Ø, 20 BHP TEFC, 230-460 VAC, 60 Hz</b>			
	<b>3:1 Constant Torque Speed Range</b>			
<b>T2</b>	211	44:1	40	100 <sup>(1)</sup>
<b>A</b>	No Drive			

<sup>(1)</sup> ( ) Fluid Viscosity Pressure Range  
 0-250 cps 0-75 psig  
 250-100,000 cps 0-116 psig

## Vector Pumps Hose Data (4000 Series)

### Construction

#### Fiber Braided:

- 1500-2000 hours Typical Life at 30 rpm  
Preferred when:
- Pumping fluids with abrasives
  - The pump is required to create a strong vacuum
  - High pressures are required

### Operating Duty

**Intermittent:** Higher pressures and higher pump speed

**Continuous:** Low pressures and lower speed

### Dimensions

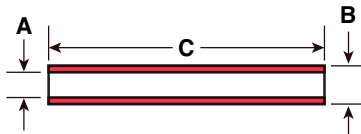

(mm)	A	B	C
4003	10	32	570
4004	15	37	830
4006	25	54	1090
4007	32	63	1300
4009	40	67	1500
4010	51	81	1820
4014	80	123	2910

### Hose Identification

#### Fiber Braided (Polyamide) 2 to 6 Layers

- Natural Rubber
- NBR, Oil-rated
- Nitrile Rubber Food Grade (NBR-F)
- EPDM
- Hypalon

#### Code

- MF White stripe
- BF Yellow stripe
- YF White & yellow stripe
- EF Red stripe
- HF Blue stripe

Material	Operating Temperatures	Industry Approvals
EPDM	32° to 185°F (0° to 85°C)	
Hypalon	32° to 180°F (0° to 82.2°C)	
Natural Rubber	14° to 185°F (-10° to 85°C)	
Nitrile (NBR) Oil-rated	14° to 176°F (-10° to 80°C)	
Nitrile (NBR) Food grade	14° to 176°F (-10° to 80°C)	Meets FDA Criteria

### ATTENTION!

When operating within 15°F (9.4°C) of maximum hose temperature, do not exceed 20 rpm pump speed. In addition, metal inspection plate is required vs. clear plastic material.

# Vector Pumps Selection Guidelines (4000 Series)

## 1. Collect application information

Fluid: \_\_\_\_\_

Discharge Press: \_\_\_\_\_ psig

Suction Condition:

Lift: \_\_\_\_\_ feet  
 or Vacuum: \_\_\_\_\_ inches of Hg  
 or Flooded: \_\_\_\_\_ feet of fluid above pump  
 or Pressurized: \_\_\_\_\_ psig

Flow or Flow Range: \_\_\_\_\_ gpm

Temperature (°F): Min: \_\_\_\_\_ Max: \_\_\_\_\_ Normal: \_\_\_\_\_

Solids?, describe: \_\_\_\_\_

Solid Size: \_\_\_\_\_

Solid Length: \_\_\_\_\_

Solids %: \_\_\_\_\_

Viscosity at Temp: \_\_\_\_\_

Vapor Pressure at Temp: \_\_\_\_\_

Specific Gravity: \_\_\_\_\_

Duty Cycle (hrs/day): \_\_\_\_\_

Motor Enclosure: \_\_\_\_\_

Hertz: 50 \_\_\_\_\_ 60 \_\_\_\_\_

Volts: \_\_\_\_\_

Phase: 1 \_\_\_\_\_ 3 \_\_\_\_\_

Motor eff: Std \_\_\_\_\_ High \_\_\_\_\_ Inverter Duty \_\_\_\_\_

Variable Frequency Drive: Yes \_\_\_\_\_ No \_\_\_\_\_

If yes, what environment will controller be mounted:

Inside another panel \_\_\_\_\_ Dry, fairly dust free \_\_\_\_\_

Dusty area \_\_\_\_\_ Wet area \_\_\_\_\_

Wash down area \_\_\_\_\_

Hazardous area \_\_\_\_\_ If yes, class and group \_\_\_\_\_

If Yes, input voltage: 120 \_\_\_\_\_ 230 \_\_\_\_\_ 460 \_\_\_\_\_

## 2. Determine the maximum roller speed

### Duty Cycle (hours/day) of operation

- See pump performance graphs

### Viscosity of the fluid

- < 200 cps: no speed correction needed
- 200-1000 cps: max. speed 40 rpm
- 1,000-5000 cps: max. speed 30 rpm; use flooded/pressurized suction
- 5,000-10,000 cps: max. speed 20 rpm; use flooded/pressurized suction
- 10,000-15,000 cps: max. speed 10 rpm; use flooded/pressurized suction

Note: With viscosities over 200 cps it is very important to oversize the suction line 1-1/2 to 2 times the pump connector size and to keep suction lines as short as possible.

**Temperature of the fluid:** If the fluid temperature pumped is within 15° F (9.4°C) of the maximum temperature rating of the hose, contact factory and select a pump with a maximum speed of 20 rpm.

## 3. Pump Selection

- Select pump that can deliver the required flow based on the maximum roller speed and discharge pressure required by the application.

Note: It may be required to select a larger pump if solids are larger than the maximum size the pump can handle.

## 4. Hose Selection

- Hose selection based on chemical compatibility and temperature.

## 5. Connector Type and Material Selection

## 6. Drive Selection

## MODEL 4003 PUMP DATA

### Performance

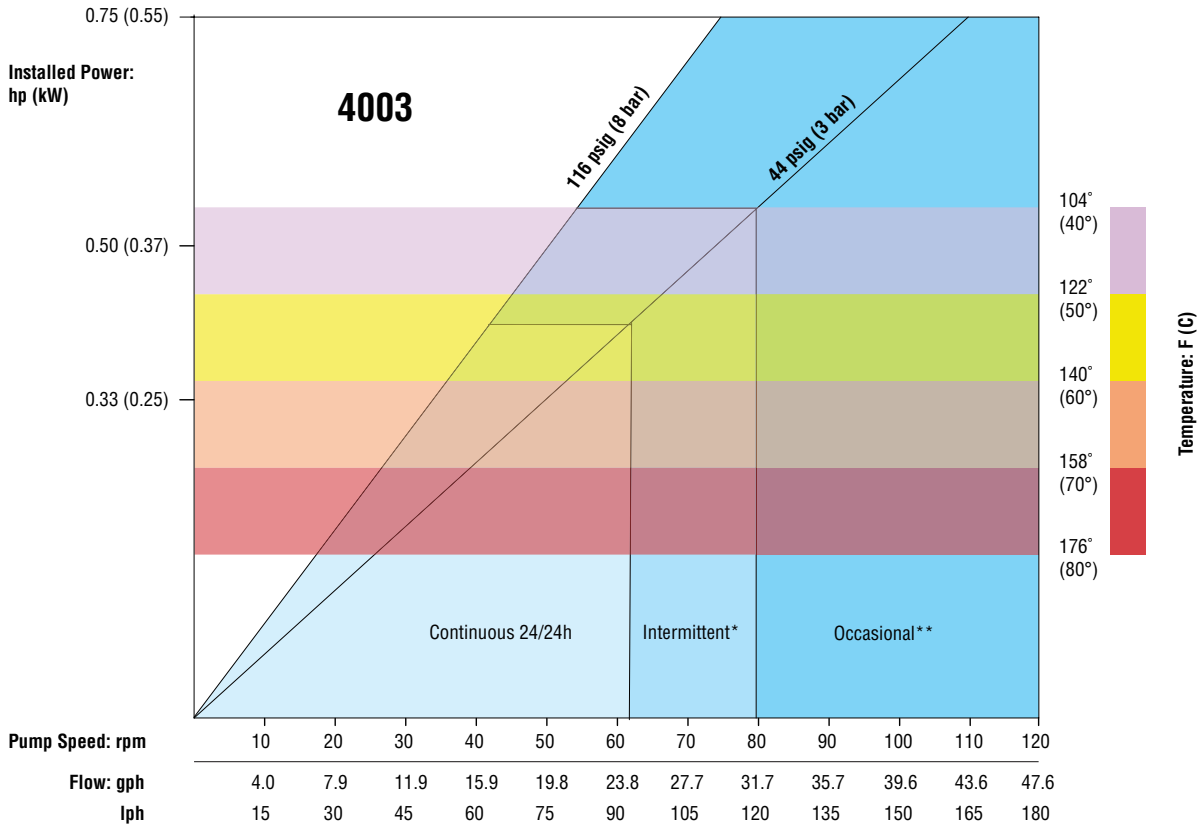

\* Intermittent use: Minimum of 1 hour stop after 2 hours use \*\* Occasional use: Maximum 1 hour per day

### Fluid Characteristics

Viscosity:	100,000 cps max.
Liquid Temperature:	180°F (82°C) max.
Solid Size:	(see page 4)
Fiber Length:	2-3/8 inch (60 mm) max.

### Materials of Construction

Casing:	Ductile Iron
Rotor:	Ductile Iron
Wheel:	Ductile Iron
Frame:	Steel
Cover:	Lexan
Casing O-ring Seal:	Nitrile
Hose Materials:	NR/NBR/EPDM/Hypalon

### Specifications

Discharge Pressure:	110 psig (7.6 bar) max.
Suction Lift (sea level):	29.5 ft (9 m) max.
Suction Pressure:	21.8 psig (1.5 bar) max.
NPSHr:	4 ft
Horsepower:*	0.75 max
Hose Size:	10 x 32 x 570 mm
Displacement:	0.0066 gal/rev
Lubrication Fluid:	.37 qts (.35 L) max.
Lubricant:	Glycerine / Glycol
Weight (pump only):	22 lbs. (10 kg)
Weight (with drive):	55 lbs. (25 kg)

\* Pumps are shaft driven and require a gearbox and motor. See Ordering Information on following page for details.

## Model 4003 Ordering Information

A complete Vector pump order number uses a 10-character order code to identify the desired hose, fittings and drive. Select the appropriate items from the chart to the right and use the order code from each group to complete the pump assembly order number.



1	2	3	4	5	6	7	8	9	10
4	0	0	3	-		-		-	

Order Digit	Order Code	Description
<b>1-4</b>	<b>4003</b>	<b>Pump Designation</b> Model 4003 Shaft Drive Pump
<b>5-6</b>		<b>Hose Material (fiber-braided)</b>
	MF	Natural Rubber
	BF	NBR, Oil-rated
	EF	EPDM
	HF	Hypalon
<b>7-8</b>		<b>Connector Material/Style</b>
	SS	316 SST 3/4" Hose Barb
	PP	Polypropylene 3/4" Hose Barb
	MM	PVDF 3/4" Hose Barb
<b>9-10</b>		<b>Drive</b>
		<b>Flow GPH</b>
		<b>Gear Ratio</b>
		<b>Pump RPM</b>
		<b>Max Psig</b>
		<b>BHP</b>
		<b>3Ø, TEFC, 230/460 VAC, 60 Hz</b>
		<b>4:1 Inverter Duty Turndown</b>
	B2	7.0      92:1      18      116*      3/4
	D2	14.0      48:1      36      116*      3/4
	F2	21.0      32:1      54      116*      3/4
	H2	27.0      25:1      69      116*      3/4
	J2	42.0      16:1      108      44      3/4

Fluid Viscosity	Pressure Range*
0 - 250 cps	0 - 75 psig
250 - 100,000 cps	0 - 116 psig

## Dimensional Drawings

See Ordering Information for motor and gearbox sizes.

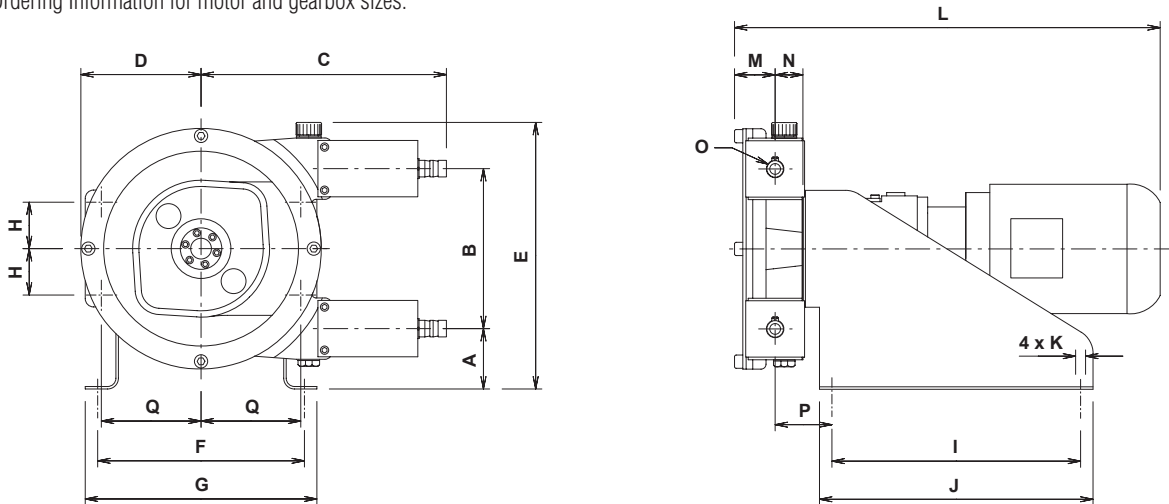

	A	B	C	D	E	F	G	H	I	J	K	M	N	O	P	Q
<b>Inches</b>	4.1	4.5	8.9	3.7	10.7	8.7	9.5	1.3	10.24	11.02		1.71	1.36		3.20	3.2
<b>mm</b>	103.5	115	225.5	95	271	220	240	33.5	260	280	4xø9	43.5	34.5	ø16	81.25	81.25

## MODEL 4004 PUMP DATA

### Performance

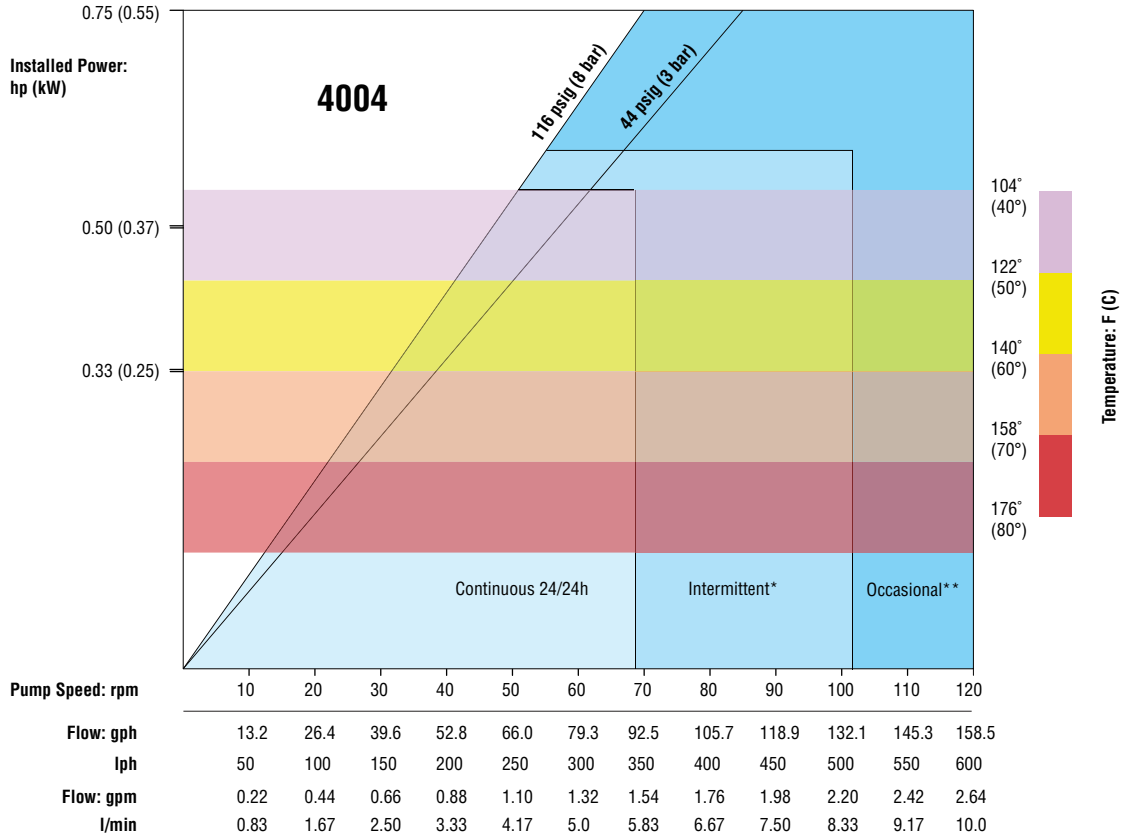

\* Intermittent use: Minimum of 1 hour stop after 2 hours use \*\* Occasional use: Maximum 1 hour per day

### Fluid Characteristics

Viscosity:	100,000 cps max.
Liquid Temperature:	180°F (82°C) max.
Solid Size:	(see page 4)
Fiber Length:	2-3/4 inch (70 mm) max.

### Materials of Construction

Casing:	Ductile Iron
Rotor:	Ductile Iron
Wheel:	Ductile Iron
Frame:	Steel
Cover:	Lexan
Casing O-ring Seal:	Nitrile
Hose Materials:	NR/NBR/EPDM/Hypalon

### Specifications

Discharge Pressure:	110 psig (7.6 bar) max.
Suction Lift (sea level):	29.5 ft (9 m) max.
Suction Pressure:	21.8 psig (1.5 bar) max.
NPSHr:	4 ft
Horsepower:*	0.75 max
Hose Size:	15 x 37 x 830 mm
Displacement:	0.022 gal/rev
Lubrication Fluid:	.42 qts (.4 L) max.
Lubricant:	Glycerine / Glycol
Weight (pump only):	49 lbs. (22 kg)
Weight (with drive):	77 lbs. (49 kg)

\* Pumps are shaft driven and require a gearbox and motor. See Ordering Information on following page for details.

## Model 4004 Ordering Information

A complete Vector pump order number uses a 10-character order code to identify the desired hose, fittings and drive. Select the appropriate items from the chart to the right and use the order code from each group to complete the pump assembly order number.



1	2	3	4	5	6	7	8	9	10
4	0	0	4	-		-		-	

Order Digit	Order Code	Description
<b>1-4</b>	<b>4004</b>	<b>Pump Designation</b> Model 4004 Shaft Drive Pump
<b>5-6</b>	<b>MF</b> <b>BF</b> <b>EF</b> <b>HF</b>	<b>Hose Material (fiber-braided)</b> Natural Rubber NBR, Oil-rated EPDM Hypalon
<b>7-8</b>	<b>SS</b> <b>PP</b> <b>MM</b>	<b>Connector Material/Style</b> 316 SST 3/4" Hose Barb Polypropylene 3/4" Hose Barb PVDF 3/4" Hose Barb
<b>9-10</b>	<b>B2</b> <b>D2</b> <b>F2</b> <b>H2</b> <b>J2</b>	<b>Drive</b> <b>Flow GPH</b> <b>Gear Ratio</b> <b>Pump RPM</b> <b>Max Psig</b> <b>BHP</b> 3Ø, TEFC, 230/460 VAC, 60 Hz 4:1 Inverter Duty Turndown 23.7 92:1 18 116* 3/4 47.2 48:1 36 116* 3/4 71.0 32:1 54 116* 1 91.0 25:1 69 100* 1 115.7 20:1 88 45 1

Fluid Viscosity	Pressure Range*
0 - 250 cps	0 - 75 psig
250 - 100,000 cps	0 - 116 psig

## Dimensional Drawings

See Ordering Information for motor and gearbox sizes.

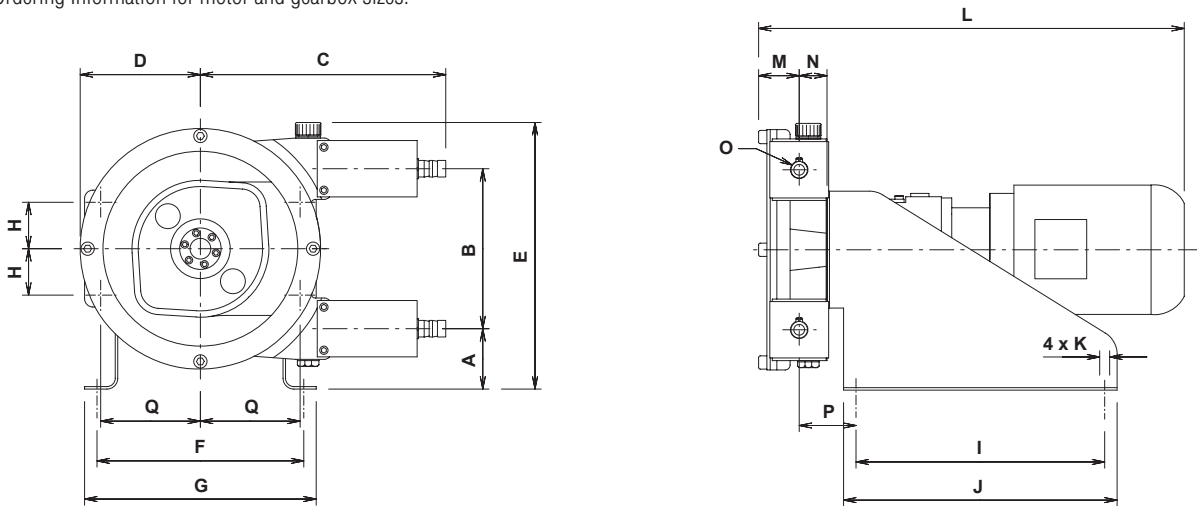

	A	B	C	D	E	F	G	H	I	J	K	M	N	O	P	Q
<b>Inches</b>	2.9	7.6	11.7	5.7	12.7	9.8	11.0	2.0	11.8	13.0	1.9	1.4		2.8	4.9	
<b>mm</b>	73	193	296	145	322	250	280	51.5	300	330	4xØ13	49	35.5	Ø20*	70.5	124.5

## MODEL 4006 PUMP DATA

### Performance

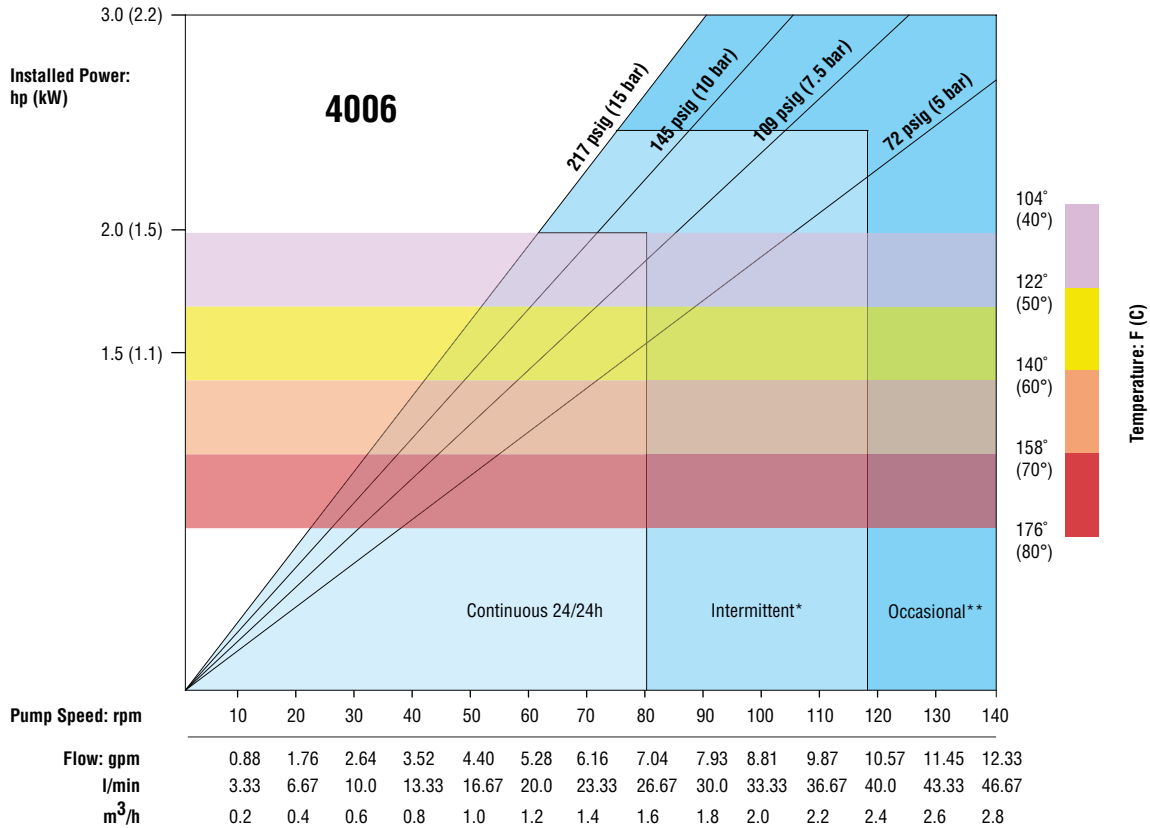

\* Intermittent use: Minimum of 1 hour stop after 2 hours use \*\* Occasional use: Maximum 1 hour per day

### Fluid Characteristics

Viscosity:	100,000 cps max.
Liquid Temperature:	180°F (82°C) max.
Solid Size:	(see page 4)
Fiber Length:	6 inch (150 mm) max.

### Materials of Construction

Casing:	Ductile Iron
Rotor:	Ductile Iron
Shoes:	Aluminium
Frame:	Steel
Cover:	Electroplated Steel
Casing O-ring Seal:	Nitrile
Hose Materials:	NR/NBR/EPDM/Hypalon

### Specifications

Discharge Pressure:	218 psig (15 bar) max.
Suction Lift (sea level):	29.5 ft (9 m) max.
Suction Pressure:	21.8 psig (1.5 bar) max.
NPSHr:	4 ft
Horsepower:*	3.0 max.
Hose Size:	25 x 54 x 1090 mm
Displacement:	0.088 gal/rev
Lubrication Fluid:	2.22 qts (2.1 L) max.
Lubricant:	Glycerine / Glycol
Weight (pump only):	112 lbs. (51 kg)
Weight (with drive):	176 lbs. (80 kg)

\* Pumps are shaft driven and require a gearbox and motor. See Ordering Information on following page for details.



## Model 4006 Ordering Information

A complete Vector pump order number uses a 10-character order code to identify the desired hose, fittings and drive. Select the appropriate items from the chart to the right and use the order code from each group to complete the pump assembly order number.



## Dimensional Drawings

See Ordering Information for motor and gearbox sizes.

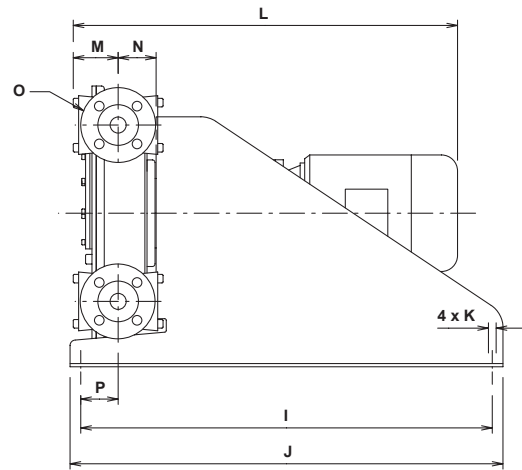
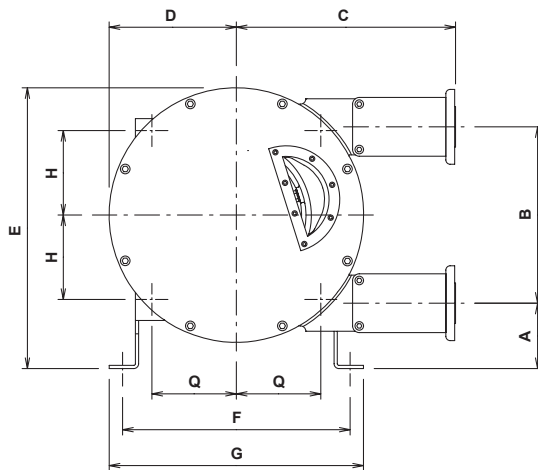

	A	B	C	D	E	F	G	H	I	J	K	M	N	O	P	Q
<b>Inches</b>	3.7	10.3	14.0	7.5	16.4	12.3	13.9	4.3	22.1	23.6	2.6	2.7	1" 150 lb	2.7	4.3	
<b>mm</b>	95	262	355.5	190	416	312	352	110	560	600	4xø13	65	69	ANSI	69	110

<b>1</b>	<b>2</b>	<b>3</b>	<b>4</b>	<b>5</b>	<b>6</b>	<b>7</b>	<b>8</b>	<b>9</b>	<b>10</b>
4	0	0	6	-		-		-	

Order Digit	Order Code	Description
<b>1-4</b>	<b>4006</b>	<b>Pump Designation</b> Model 4006 Shaft Drive Pump
<b>5-6</b>	<b>MF</b> <b>BF</b> <b>EF</b> <b>HF</b>	<b>Hose Material (fiber-braided)</b> Natural Rubber NBR, Oil-rated EPDM Hypalon
<b>7-8</b>	<b>BB</b> <b>PP</b> <b>MM</b>	<b>Connector Material/Style</b> 316 SST insert w/ 316 SST 1" 150 Lb ANSI flange Polypropylene insert w/ 316 SST 1" 150 Lb ANSI flange PVDF insert w/ 316 SST 1" 150 Lb ANSI flange
<b>9-10</b>	<b>B2</b> <b>D2</b> <b>F2</b> <b>H2</b> <b>J2</b> <b>K2</b>	<b>Drive</b> <b>Flow GPM</b> <b>Gear Ratio</b> <b>Pump RPM</b> <b>Max Psig</b> <b>BHP</b> <b>3Ø, TEFC, 230/460 VAC, 60 Hz</b> <b>4:1 Inverter Duty Turndown</b> 1.5 97:1 18 217* 1.5 2 54:1 32 217* 2 3 39:1 45 217* 3 3 28:1 63 217* 3 3 20:1 87 140* 3 3 17:1 100 140* 3

Fluid Viscosity	Pressure Range*
0 - 250 cps	0 - 75 psig
250 - 100,000 cps	0 - 217 psig

## MODEL 4007 PUMP DATA

### Performance

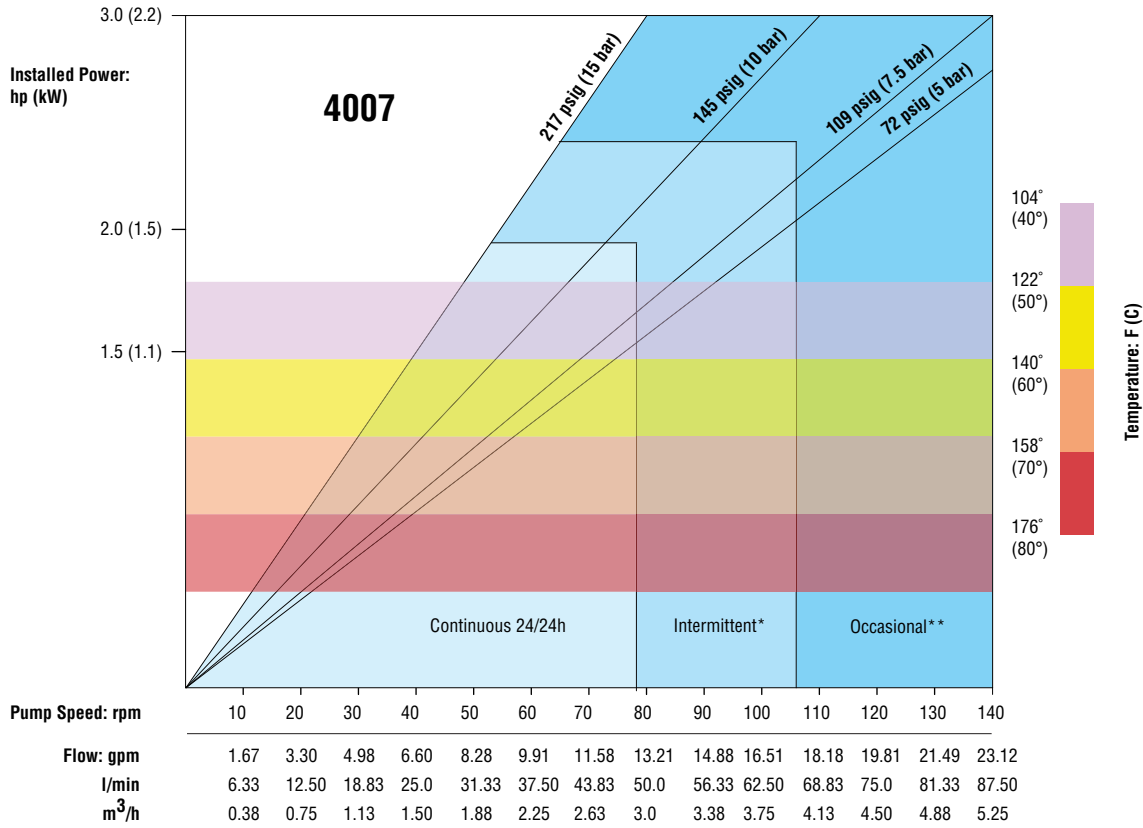

### Fluid Characteristics

Viscosity:	100,000 cps max.
Liquid Temperature:	180°F (82°C) max.
Solid Size:	(see page 4)
Fiber Length:	7-7/8 inch (300 mm) max.

### Materials of Construction

Casing:	Ductile Iron
Rotor:	Ductile Iron
Shoes:	Aluminium
Frame:	Steel
Cover:	Electroplated Steel
Casing O-ring Seal:	Nitrile
Hose Materials:	NR/NBR/EPDM/Hypalon

### Specifications

Discharge Pressure:	218 psig (15 bar) max.
Suction Lift (sea level):	29.5 ft (9 m) max.
Suction Pressure:	21.8 psig (1.5 bar) max.
NPSHr:	4 ft
Horsepower:*	3.0 max.
Hose Size:	32 x 63 x 1300 mm
Displacement:	0.165 gal/rev
Lubrication Fluid:	2.64 qts (2.5 L)
Lubricant:	Glycerine / Glycol
Weight (pump only):	194 lbs. (88 kg)
Weight (with drive):	287 lbs. (130 kg)

\* Pumps are shaft driven and require a gearbox and motor.  
See Ordering Information on following page for details.

## Model 4007 Ordering Information

A complete Vector pump order number uses a 10-character order code to identify the desired hose, fittings and drive. Select the appropriate items from the chart to the right and use the order code from each group to complete the pump assembly order number.



1	2	3	4	5	6	7	8	9	10
4	0	0	7	-		-		-	

Order Digit	Order Code	Description
<b>1-4</b>		<b>Pump Designation</b>
	4007	Model 4007 Shaft Drive Pump
<b>5-6</b>		<b>Hose Material (fiber-braided)</b>
	MF	Natural Rubber
	BF	NBR, Oil-rated
	EF	EPDM
	HF	Hypalon
<b>7-8</b>		<b>Connector Material/Style</b>
	BB	316 SST insert w/ 316 SST 1-1/2" 150 Lb ANSI flange
	PP	Polypropylene insert w/ 316 SST 1-1/2" 150 Lb ANSI flange
	MM	PVDF insert w/ 316 SST 1-1/2" 150 Lb ANSI flange
<b>9-10</b>		<b>Drive</b>
		<b>Flow GPM</b>
		<b>Gear Ratio</b>
		<b>Pump RPM</b>
		<b>Max Psig</b>
		<b>BHP</b>
		<b>3Ø, TEFC, 230/460 VAC, 60 Hz</b>
		<b>4:1 Inverter Duty Turndown</b>
	B2	2.9 97:1 18 217* 1.5
	D2	5.3 54:1 32 217* 2
	F2	7.4 39:1 45 217* 3
	H2	10.4 28:1 63 217* 3
	J2	14.3 20:1 87 140* 3
	K2	16.5 17:1 100 140* 3

## Dimensional Drawings

See Ordering Information for motor and gearbox sizes.

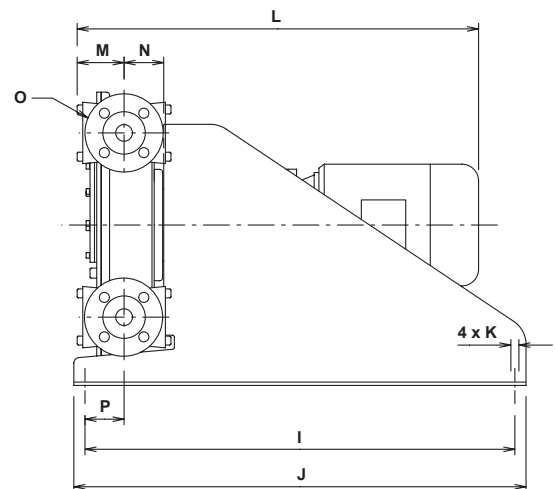
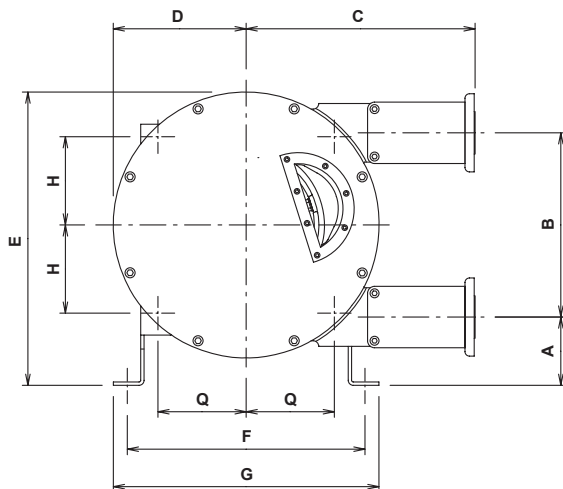

	A	B	C	D	E	F	G	H	I	J	K	M	N	O	P	Q
<b>Inches</b>	4.8	13.0	17.2	9.4	20.7	16.8	18.7	6.2	30.3	31.9	3.3	3.5	1.5" 150 lb	3.6	6.2	
<b>mm</b>	122.5	330	435.5	238	525.5	426	476	157.75	770	810	4xØ13	83	89	ANSI	91	157.75

## MODEL 4009 PUMP DATA

### Performance

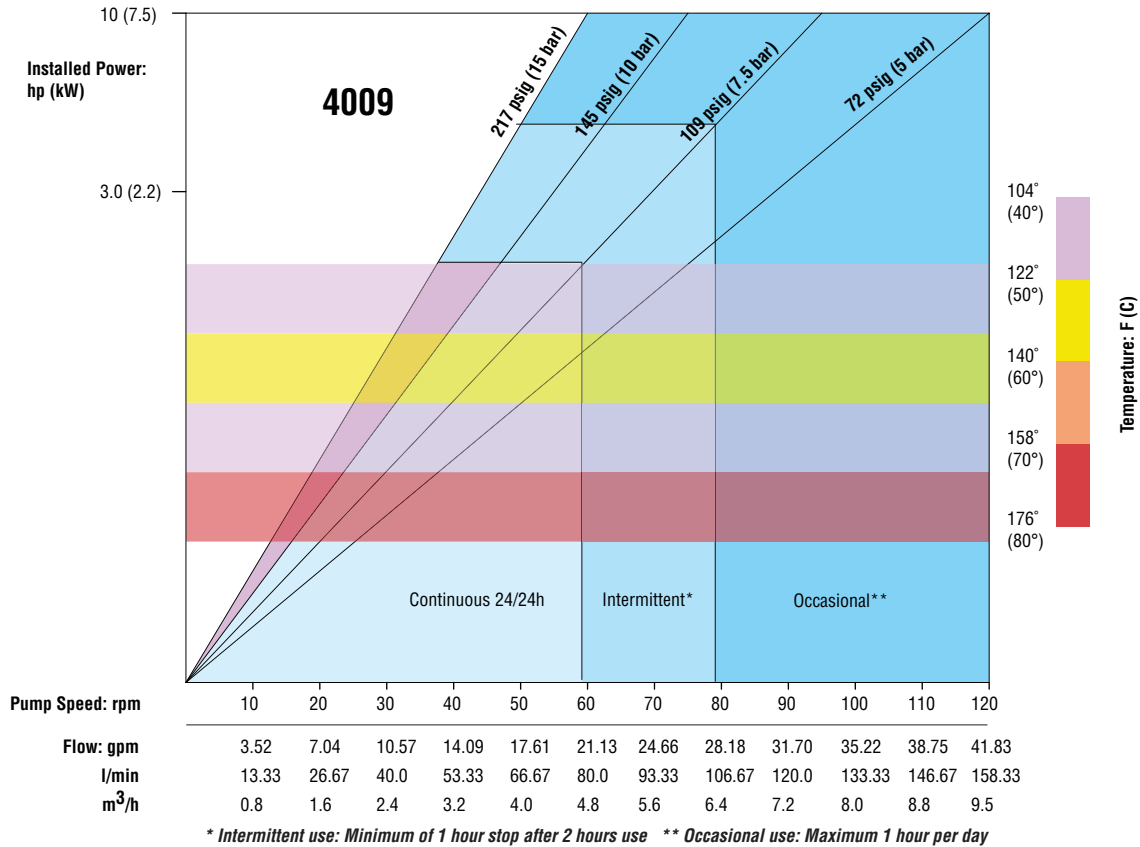

### Fluid Characteristics

Viscosity:	100,000 cps max.
Liquid Temperature:	180°F (82°C) max.
Solid Size:	(see page 4)
Fiber Length:	11-7/8 inch (300 mm) max.

### Materials of Construction

Casing:	Ductile Iron
Rotor:	Ductile Iron
Shoes:	Aluminium
Frame:	Steel
Cover:	Steel
Casing O-ring Seal:	Nitrile
Hose Materials:	NR/NBR/EPDM/Hypalon

### Specifications

Discharge Pressure:	218 psig (15 bar) max.
Suction Lift (sea level):	29.5 ft (9 m) max.
Suction Pressure:	21.8 psig (1.5 bar) max.
NPSHr:	4 ft
Horsepower:*	5.0 max.
Hose Size:	40 x 67 x 1500 mm
Displacement:	0.352 gal/rev
Lubrication Fluid:	5.28 qts (5 L)
Lubricant:	Glycerine / Glycol.
Weight (pump only):	203 lbs. (92 kg)
Weight (with drive):	463 lbs. (210 kg)

\* Pumps are shaft driven and require a gearbox and motor.  
 See Ordering Information on following page for details.

## Model 4009 Ordering Information

A complete Vector pump order number uses a 10-character order code to identify the desired hose, fittings and drive. Select the appropriate items from the chart to the right and use the order code from each group to complete the pump assembly order number.



## Dimensional Drawings

See Ordering Information for motor and gearbox sizes.

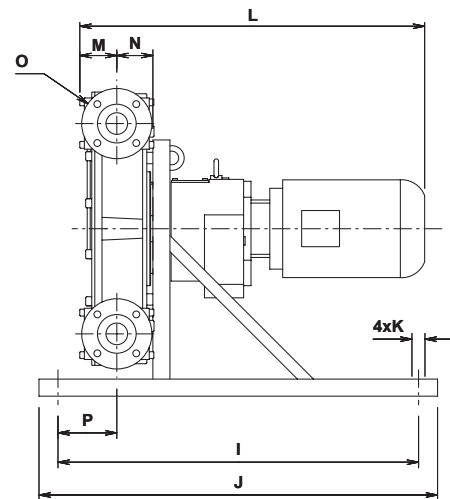
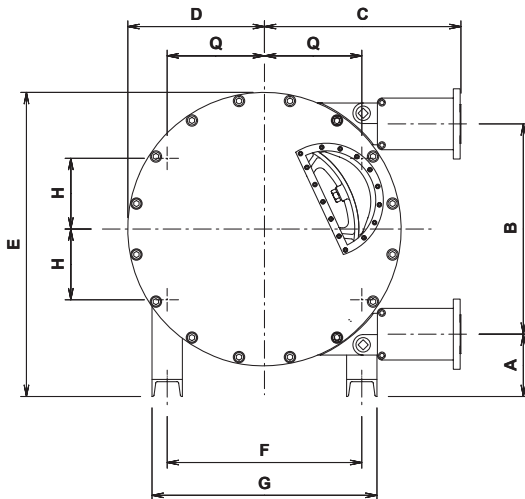

	A	B	C	D	E	F	G	H	I	J	K	M	N	O	P	Q
<b>Inches</b>	4.3	16.9	15.8	11.5	24.3	13.4	16.5	6.7	33.5	37.4		2.9	3.5	1.5" 150 lb	3.4	6.7
<b>mm</b>	110	430	400	291	616	340	420	170	850	950	4xø19	73	88	ANSI	87	170

<b>1</b>	<b>2</b>	<b>3</b>	<b>4</b>	<b>5</b>	<b>6</b>	<b>7</b>	<b>8</b>	<b>9</b>	<b>10</b>
4	0	0	9	-		-		-	

Order Digit	Order Code	Description
-------------	------------	-------------

<b>1-4</b>	<b>Pump Designation</b>	
	<b>4009</b>	Model 4009 Shaft Drive Pump

<b>5-6</b>	<b>Hose Material (fiber-braided)</b>	
	<b>MF</b>	Natural Rubber
	<b>BF</b>	NBR, Oil-rated
	<b>EF</b>	EPDM
	<b>HF</b>	Hypalon

<b>7-8</b>	<b>Connector Material/Style</b>	
	<b>BB</b>	316 SST insert w/ 316 SST 1-1/2" 150 Lb ANSI flange
	<b>PP</b>	Polypropylene insert w/ 316 SST 1-1/2" 150 Lb ANSI flange
	<b>MM</b>	PVDF insert w/ 316 SST 1-1/2" 150 Lb ANSI flange

<b>9-10</b>	<b>Drive</b>				
	<b>Flow GPM</b>	<b>Gear Ratio</b>	<b>Pump RPM</b>	<b>Max Psig</b>	<b>BHP</b>
	<b>3Ø, TEFC, 230/460 VAC, 60 Hz</b>				
	<b>4:1 Inverter Duty Turndown</b>				
	<b>B2</b>	8.4	72:1	24	217*
	<b>D2</b>	12.6	49:1	36	217*
	<b>F2</b>	15.8	39:1	45	217*
	<b>H2</b>	19.0	32:1	54	160*
	<b>J2</b>	24.7	25:1	70	120*
	<b>K2</b>	35.9	17:1	102	72

<b>Fluid Viscosity</b>	<b>Pressure Range*</b>
0 - 250 cps	0 - 75 psig
250 - 100,000 cps	0 - 217 psig

## MODEL 4010 PUMP DATA

### Performance

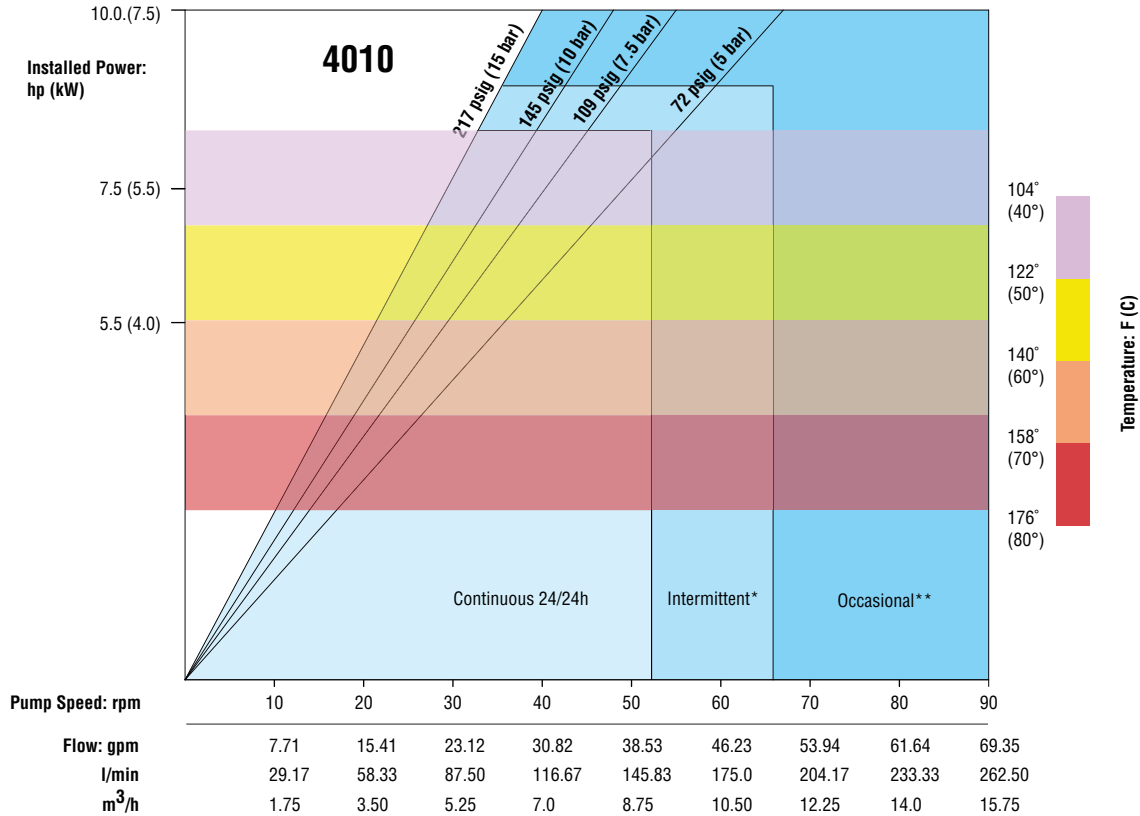

### Fluid Characteristics

Viscosity:	100,000 cps max.
Liquid Temperature:	180°F (82°C) max.
Solid Size:	(see page 4)
Fiber Length:	19-5/8 inch (500 mm) max.

### Materials of Construction

Casing:	Ductile Iron
Rotor:	Ductile Iron
Shoes:	Cast Iron
Frame:	Steel
Cover:	Steel
Casing O-ring Seal:	Nitrile
Hose Materials:	NR/NBR/EPDM/Hypalon

### Specifications

Discharge Pressure:	218 psig (15 bar) max.
Suction Lift (sea level):	29.5 ft (9 m) max.
Suction Pressure:	21.8 psig (1.5 bar) max.
NPSHr:	4 ft
Horsepower:*	10 max.
Hose Size:	51 x 81 x 1820 mm
Displacement:	0.77 gal/rev
Lubrication Fluid:	10.57 qts (10 L)
Lubricant:	Glycerine / Glycol
Weight (pump only):	430 lbs. (195 kg)
Weight (with drive):	694 lbs. (315 kg)

\* Pumps are shaft driven and require a gearbox and motor.  
 See Ordering Information on following page for details.

## Model 4010 Ordering Information

A complete Vector pump order number uses a 10-character order code to identify the desired hose, fittings and drive. Select the appropriate items from the chart to the right and use the order code from each group to complete the pump assembly order number.



1	2	3	4	5	6	7	8	9	10
4	0	1	0	-		-		-	

Order Digit	Order Code	Description				
<b>1-4</b>	<b>4010</b>	<b>Pump Designation</b> Model 4010 Shaft Drive Pump				
<b>5-6</b>		<b>Hose Material (fiber-braided)</b>				
	MF	Natural Rubber				
	BF	NBR, Oil-rated				
	EF	EPDM				
	HF	Hypalon				
<b>7-8</b>		<b>Connector Material/Style</b>				
	BB	316 SST insert w/ 316 SST 2" 150 Lb ANSI flange				
	PP	Polypropylene insert w/ 316 SST 2" 150 Lb ANSI flange				
	MM	PVDF insert w/ 316 SST 2" 150 Lb ANSI flange				
<b>9-10</b>		<b>Drive</b>				
		<b>Flow GPM</b>				
		<b>Gear Ratio</b>				
		<b>Pump RPM</b>				
		<b>Max Psig</b>				
		<b>BHP</b>				
		<b>3Ø, TEFC, 230/460 VAC, 60 Hz</b>				
		<b>4:1 Inverter Duty Turndown</b>				
	B2	19.0	71:1	25	217*	7.5
	D2	26.9	50:1	35	217*	10
	F2	36.9	37:1	48	100*	10
	H2	47.7	28:1	62	72	10
	J2	58.5	23:1	76	45	10

## Dimensional Drawings

See Ordering Information for motor and gearbox sizes.

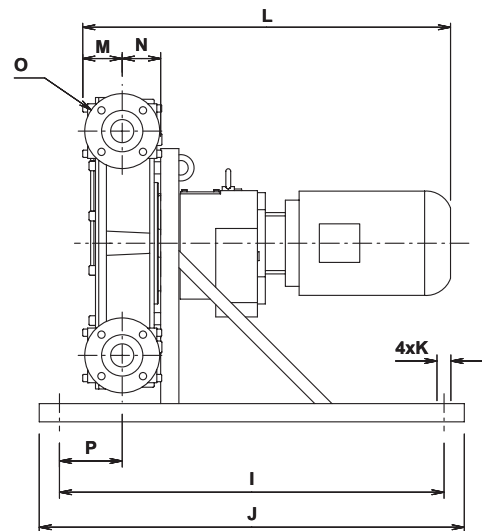
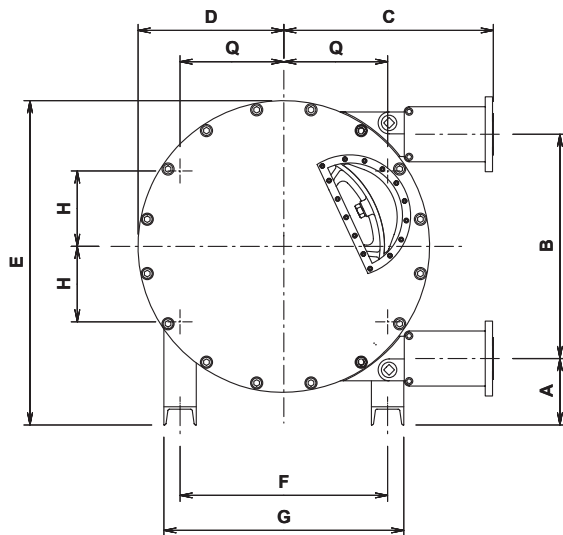

	A	B	C	D	E	F	G	H	I	J	K	M	N	O	P	Q
<b>Inches</b>	6.5	21.8	20.4	14.2	31.6	20.2	23.4	7.3	37.4	41.3	3.8	4.0	2" lb	6.4	10.1	
<b>mm</b>	164.5	554	517.5	360	801.5	513	593	186	950	1050	4xØ19	97.5	102	ANSI	162	256.5

## MODEL 4014 PUMP DATA

### Performance

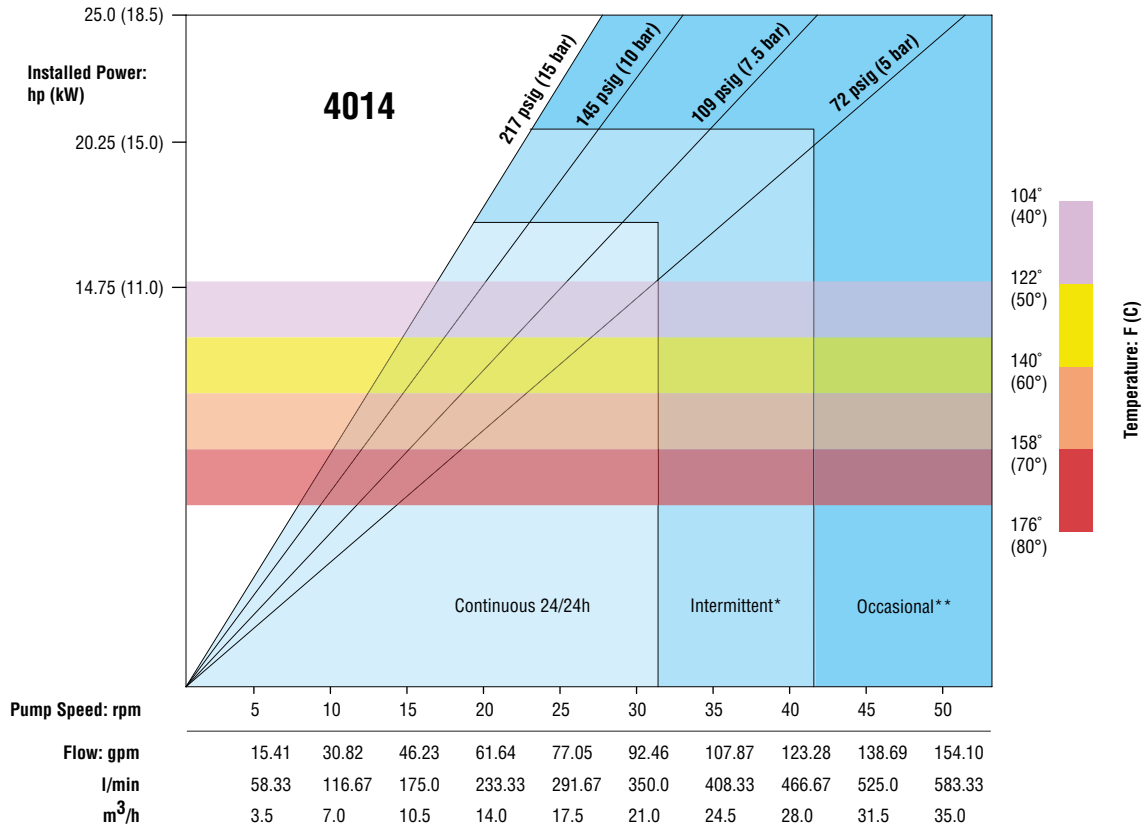

### Fluid Characteristics

Viscosity:	100,000 cps max.
Liquid Temperature:	180°F (82°C) max.
Solid Size:	(see page 4)
Fiber Length:	39-5/8 inch (1000 mm) max.

### Materials of Construction

Casing:	Ductile Iron
Rotor:	Ductile Iron
Shoes:	Cast Iron
Frame:	Steel
Cover:	Steel
Casing O-ring Seal:	Nitrile
Hose Materials:	NR/NBR/EPDM/Hypalon

### Specifications

Discharge Pressure:	218 psig (15 bar) max.
Suction Lift (sea level):	29.5 ft (9 m) max.
Suction Pressure:	21.8 psig (1.5 bar) max.
NPSHr:	4 ft
Horsepower:*	25 max.
Hose Size:	80 x 123 x 2910 mm
Displacement:	3.0823 gal/rev
Lubrication Fluid:	42.27 qts (40 L)
Lubricant:	Glycerine / Glycol
Weight (pump only):	1,323 lbs. (600 kg)
Weight (with drive):	2,050 lbs. (930 kg)

\* Pumps are shaft driven and require a gearbox and motor.  
See Ordering Information on following page for details.



## Model 4014 Ordering Information

A complete Vector pump order number uses a 10-character order code to identify the desired hose, fittings and drive. Select the appropriate items from the chart to the right and use the order code from each group to complete the pump assembly order number.



## Dimensional Drawings

See Ordering Information for motor and gearbox sizes.

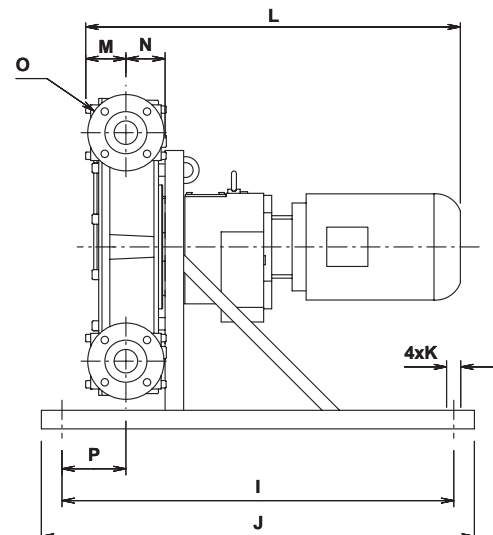
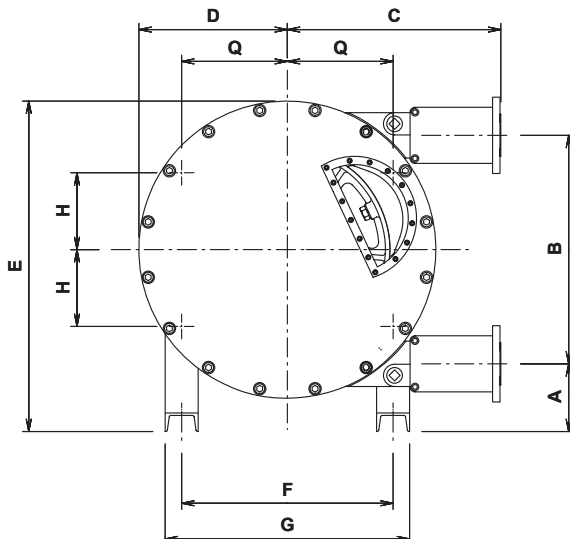

	A	B	C	D	E	F	G	H	I	J	K	M	N	O	P	Q
<b>Inches</b>	10.3	34.5	31.6	21.9	52.0	27.2	32.7	13.6	10.3	34.5		5.5	5.6	3" 150 lb	8.3	13.6
<b>mm</b>	262	876	803	555	1320	690	830	345	262	876	4xø27	140.5	145	ANSI	210	345

1	2	3	4	5	6	7	8	9	10
4	0	1	4	-		-		-	

Order Digit	Order Code	Description				
<b>1-4</b>		<b>Pump Designation</b>				
	4014	Model 4014 Shaft Drive Pump				
<b>5-6</b>		<b>Hose Material (fiber-braided)</b>				
	MF	Natural Rubber				
	BF	NBR, Oil-rated				
	EF	EPDM				
	HF	Hypalon				
<b>7-8</b>		<b>Connector Material/Style</b>				
	BB	316 SST insert w/ 316 SST 3" 150 Lb ANSI flange				
	PP	Polypropylene insert w/ 316 SST 3" 150 Lb ANSI flange				
	MM	PVDF insert w/ 316 SST 3" 150 Lb ANSI flange				
<b>9-10</b>		<b>Drive</b>				
		<b>Flow GPM</b>				
		<b>Gear Ratio</b>				
		<b>Pump RPM</b>				
		<b>Max Psig</b>				
		<b>BHP</b>				
		<b>3Ø, TEFC, 230/460 VAC, 60 Hz</b>				
		<b>4:1 Inverter Duty Turndown</b>				
	B2	46.2	120:1	15	217*	15
	D2	63.0	83:1	21	217*	20
	F2	89.3	61:1	29	140*	25
	H2	117.0	46:1	38	108*	25
	J2	135.5	40:1	44	72	25

Fluid Viscosity	Pressure Range*
0 - 250 cps	0 - 75 psig
250 - 100,000 cps	0 - 217 psig

## Accessories

### Controllers

Controllers regulate the motor speed and strokes per minute, providing a flow that is proportional to the motor speed.

### Selection Process

1. Ensure that the phase and enclosure match your application.
2. Using the appropriate chart below, select the controller hp based on the hp of your motor.
3. Match the output voltage to the output voltage of your motor.
4. Match the input voltage to your electrical source.



### 1 Phase

HP	Type	Input Voltage/Phase	Output Voltage/Phase	Enclosure	Part Number	Weight (lbs.)
1/2	Sensorless Vector	230 volt/1-phase	230 volt/3-phase	NEMA 1	C50N1-1P3P-230	2.2
1	Micro AC Inverter	115 volt / 1-phase	230 volt / 3-phase	IP-20	C100IP-1P3P-115	2.0
1	Micro AC Inverter	115 volt / 1-phase	230 volt / 3-phase	NEMA 4	C100N4-1P3P-115	8.0
1	Sensorless Vector	230 volt / 1-phase	230 volt / 3-phase	NEMA 1	C100N1-1P3P-230	2.2
1	Micro AC Inverter	230 volt / 1-phase	230 volt / 3-phase	NEMA 4	C100N4-1P3P-230	8.0
2	Sensorless Vector	230 volt / 1-phase	230 volt / 3-phase	NEMA 1	C200N1-1P3P-230	4.4
3	Sensorless Vector	230 volt / 1-phase	230 volt / 3-phase	NEMA 1	C300N1-1P3P-230	4.4

## Controllers

### 3 Phase

HP	Type	Input Voltage/Phase	Output Voltage/Phase	Enclosure	Part Number	Weight (lbs.)
1/2	Sensorless Vector	230 volt / 3-phase	230 volt / 3-phase	NEMA 1	C50N1-3P3P-230	2.2
1	Sensorless Vector	230 volt / 3-phase	230 volt / 3-phase	NEMA 1	C100N1-3P3P-230	2.2
2	Sensorless Vector	230 volt / 3-phase	230 volt / 3-phase	NEMA 1	C200N1-3P3P-230	4.4
2	Micro AC Inverter	230 volt / 3-phase	230 volt / 3-phase	NEMA 4	C200N4-3P3P-230	14.0
3	Sensorless Vector	230 volt / 3-phase	230 volt / 3-phase	NEMA 1	C300N1-3P3P-230	4.4
5	Sensorless Vector	230 volt / 3-phase	230 volt / 3-phase	NEMA 1	C500N1-3P3P-230	5.0
7-1/2	Sensorless Vector	230 volt / 3-phase	230 volt / 3-phase	NEMA 1	C750N1-3P3P-230	13.0
10	Sensorless Vector	230 volt / 3-phase	230 volt / 3-phase	NEMA 1	C1000N1-3P3P-230	13.0
1	Sensorless Vector	460 volt / 3-phase	460 volt / 3-phase	NEMA 1	C100N1-3P3P-460	2.2
1	Micro AC Inverter	460 volt / 3-phase	460 volt / 3-phase	NEMA 4	C100N4-3P3P-460	13.0
2	Sensorless Vector	460 volt / 3-phase	460 volt / 3-phase	NEMA 1	C200N1-3P3P-460	2.2
2	Micro AC Inverter	460 volt / 3-phase	460 volt / 3-phase	NEMA 4	C200N4-3P3P-460	14.0
3	Sensorless Vector	460 volt / 3-phase	460 volt / 3-phase	NEMA 1	C300N1-3P3P-460	4.4
5	Sensorless Vector	460 volt / 3-phase	460 volt / 3-phase	NEMA 1	C500N1-3P3P-460	4.4
7-1/2	Sensorless Vector	460 volt / 3-phase	460 volt / 3-phase	NEMA 1	C750N1-3P3P-460	14.0
10	Sensorless Vector	460 volt / 3-phase	460 volt / 3-phase	NEMA 1	C1000N1-3P3P-460	14.0
15	Sensorless Vector	460 volt / 3-phase	460 volt / 3-phase	NEMA 1	C1500N1-3P3P-460	14.0
20	Sensorless Vector	460 volt / 3-phase	460 volt / 3-phase	NEMA 1	C2000N1-3P3P-460	28.0
30	Sensorless Vector	460 volt / 3-phase	460 volt / 3-phase	NEMA 1	C3000N1-3P3P-460	30.0

## Pulsation Dampeners



The HP line of pulsation dampeners will reduce vibrations and water hammer in system piping.

Dampener Model	Pump Models	Connection Sizes
HP-20	2004, 4003, 4004, 4005	3/4" Hose Barb, 316 SST
HP-40	2005, 3005, 2006, 4006, 4009	1" or 1.5" 150 lb ANSI Flange, 316 SST
HP-50	2007, 4014, 4011	2" or 2.5" 150 lb ANSI Flange, 316 SST
HP-100	2008, 2009, 4013, 4014, 4015	3" or 4" 150 lb ANSI Flange, 316 SST
HP-125	2010, 4016	5" 150 lb ANSI Flange, 316 SST

### Inside hose bladder materials available:

- Natural Rubber
- EPDM
- Oil-rated Nitrile
- Hypalon

## Hose Rupture Detector

A hose rupture detector is designed to provide early indication of hose failure.

A leak detector pressure switch can be installed to measure pressure inside the pump casing. If pressure increases inside the pump casing, a signal can be used to disable the pump and notify personnel.

Contact the factory to discuss your specific application.



## Other Wanner Engineering Pumps

**Hydra-Cell**<sup>®</sup>  
*Seal-less Pumps*

[www.Hydra-Cell.com](http://www.Hydra-Cell.com)



Original FIM/DIH Series pumps

T100 Series high-horsepower pumps

Q155 Series quintuplex pumps

**Hydra-Cell**<sup>®</sup>  
**METERING SOLUTIONS**<sup>™</sup>

[www.Hydra-Cell.com/metering](http://www.Hydra-Cell.com/metering)



P Series "pulse-less" metering pumps

MTS Series triplex metering pumps

S Series solenoid-diaphragm metering pumps

**STAN-COR**

[www.StancorPump.com](http://www.StancorPump.com)

Stan-Cor Series ANSI centrifugal pumps



**VECTOR**

[www.VectorPump.com](http://www.VectorPump.com)

Vector Series peristaltic pumps





Vector pumps process difficult fluids in many industries including ceramics, building and construction, and electrical products.

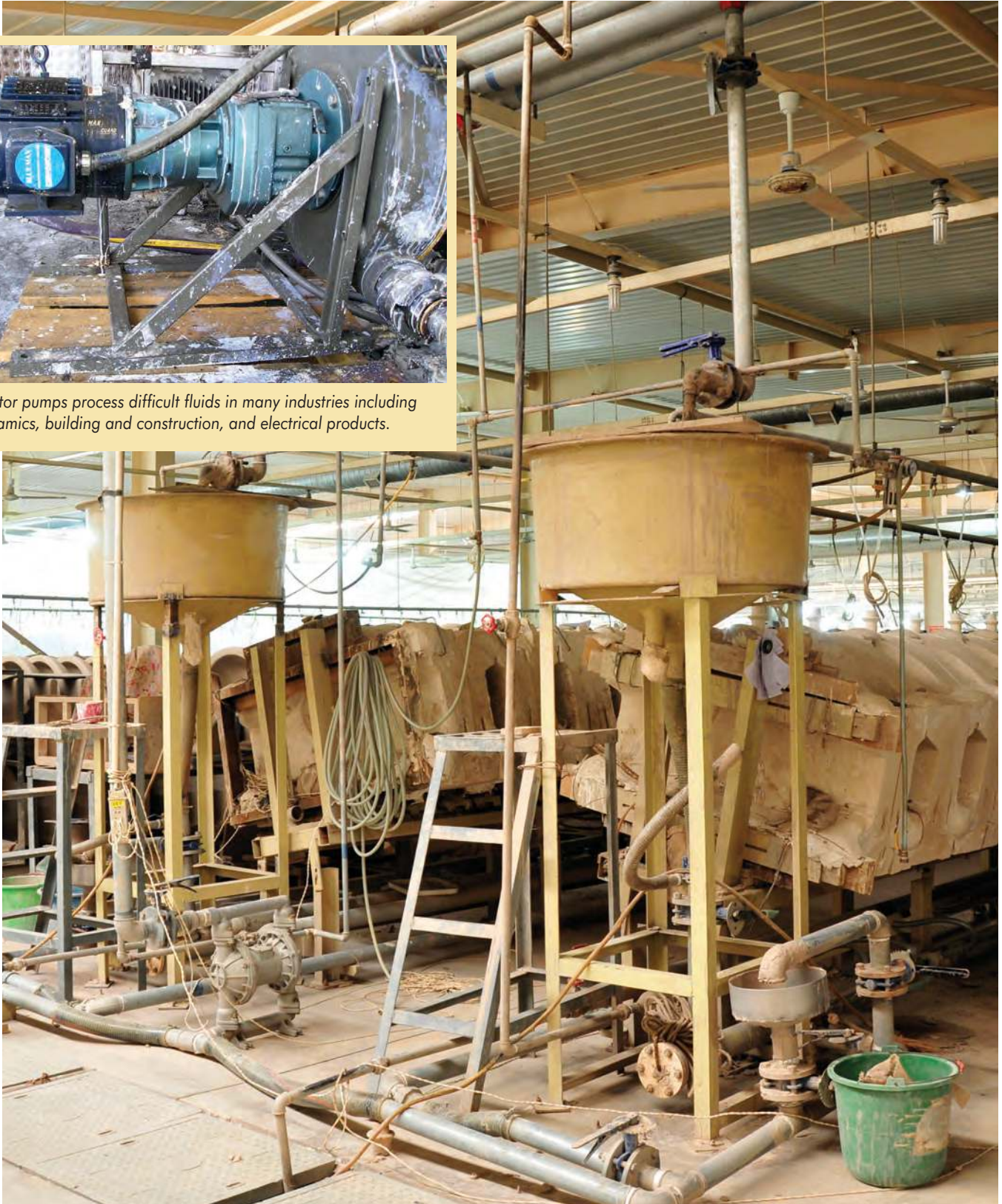

# VECTOR



## PERISTALTIC PUMPS



**Wanner Engineering, Inc.**

**World Headquarters**

Wanner Engineering, Inc.  
1204 Chestnut Avenue  
Minneapolis, MN 55403 USA  
Phone: 612-332-5681 • Fax: 612-332-6937  
Email: [sales@wannereng.com](mailto:sales@wannereng.com) • [www.WannerEng.com](http://www.WannerEng.com)

**Regional Office**

207 US Highway 281  
Wichita Falls, TX 76310 USA  
Phone: 940-322-7111 • Toll-Free: 800-234-1384  
Email: [sales@wannereng.com](mailto:sales@wannereng.com) • [www.WannerEng.com](http://www.WannerEng.com)

**Latin American Office**

R. Álvaro Anes, 150 Bairro Campestre  
Santo André/São Paulo, Brazil - CEP 09070-030  
Phone: +55 (1) 4081-7098  
Email: [mmagoni@wannereng.com](mailto:mmagoni@wannereng.com)  
[www.Hydra-Cell.com](http://www.Hydra-Cell.com)



**Wanner International Ltd.**

Wanner International, Ltd.  
Hampshire - United Kingdom  
Phone: +44 (0) 1252 816847  
Email: [sales@wannerint.com](mailto:sales@wannerint.com)  
[www.Hydra-Cell.eu](http://www.Hydra-Cell.eu)



**Wanner Pumps Ltd.**

Wanner Pumps, Ltd.  
Kowloon - Hong Kong  
Phone: +852 3428 6534  
Email: [sales@wannerpumps.com](mailto:sales@wannerpumps.com)  
[www.WannerPumps.com](http://www.WannerPumps.com)

Shanghai - China  
Phone: +86-21-6876 3700  
Email: [sales@wannerpumps.com](mailto:sales@wannerpumps.com)  
[www.WannerPumps.com](http://www.WannerPumps.com)