

Hydra-Cell®

Seal-less Pumps

Versatile, Reliable Pumps for a Wide Range of Applications



D35 Series

- Pumps the full spectrum of low-to-high viscosity fluids.
- Features a seal-less design and horizontal disk check valves that enable the pump to handle abrasives and particulates that might damage or destroy other types of pumps.
- Simple, compact design reduces initial investment and lowers maintenance costs.
- Operational efficiencies reduce energy costs.
- Able to run dry without damage (or additional maintenance) to the pump in case of accident or operator error.
- Tolerates non-ideal operating conditions.
- Minimizes maintenance and downtime because there are no mechanical or dynamic seals, packing, or cups to leak, wear, or replace.

D35 Series

Maximum Flow Rate: 36.5 gpm (138 l/min)

Maximum Pressure: 1500 psi (103 bar) for Metallic Pump Heads



D35 with 316L Stainless Steel pump head.



D35 with Brass pump head.

D35 Series Performance

Capacities

Flow

Model	Max. Input rpm	Max. Flow	
		@ 1200 psi (83 bar) gpm	l/min
D35-X	1050	36.5	138
D35-E	1150	34.0	129

@ 1500 psi (103 bar)			
D35-X	700	23.1	87.5

Pressure

Maximum Inlet Pressure

250 psi (17 bar) with 1500 psi (103 bar) maximum discharge pressure
 500 psi (34 bar) with 1200 psi (83 bar) maximum discharge pressure

Maximum Discharge Pressure

1200 psi (83 bar) @ 1150 rpm max.
 1500 psi (103 bar) @ 700 rpm max.

Performance and specification ratings apply to D35 configurations unless specifically noted otherwise.

Maximum Flow at Designated Pressure

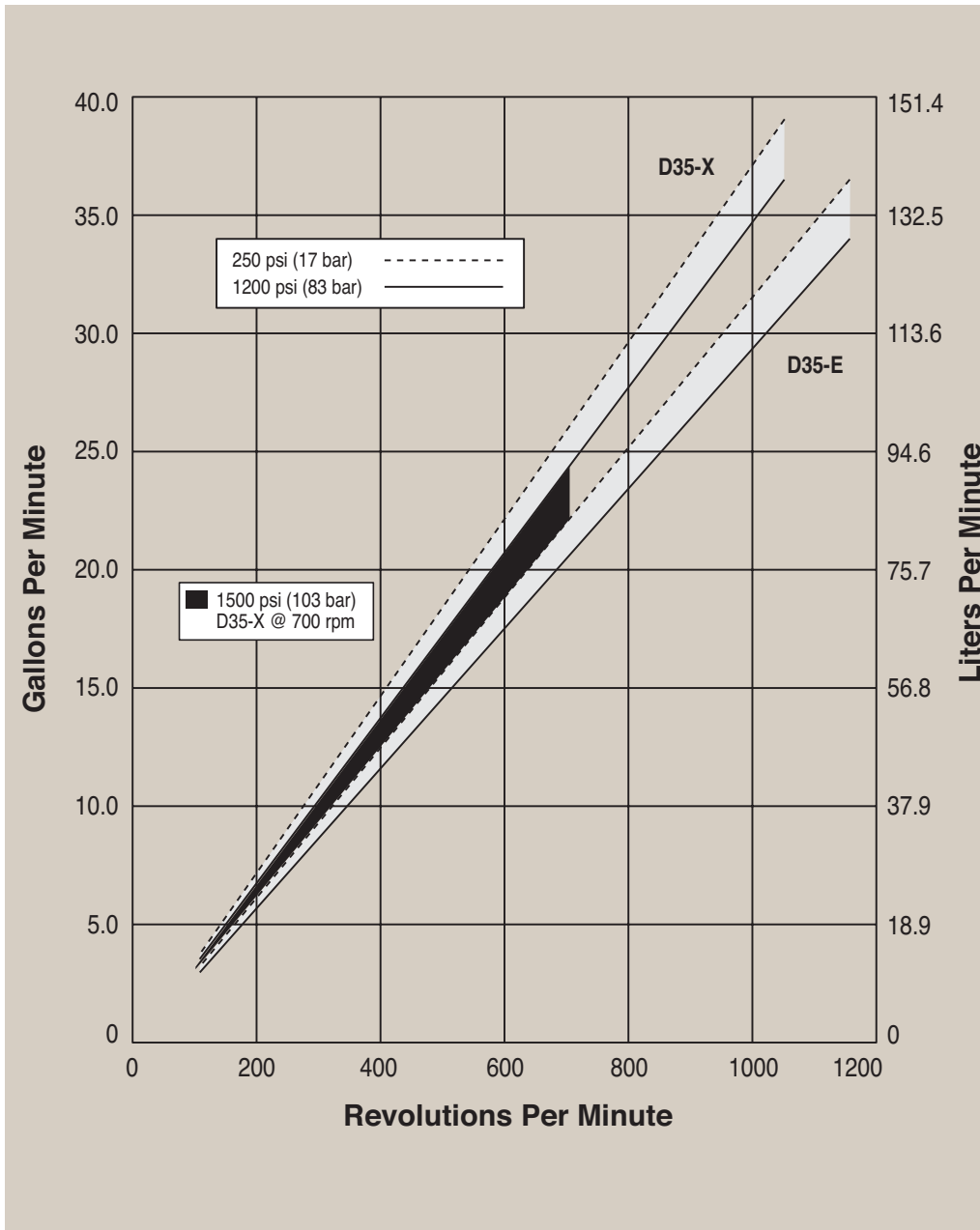

D35 Series Specifications

Flow Capacities @ 1200 psi (83 bar)

Model	rpm	gpm	l/min
D35-X	1050	36.5	138
D35-E	1150	34.0	129

Delivery @ 1200 psi (83 bar)

Model	gal/rev	liters/rev
D35-X	0.0347	0.1314
D35-E	0.0296	0.1120

Delivery @ 1500 psi (103 bar)

Model	gal/rev	liters/rev
D35-X	0.0330	0.1250

Maximum Discharge Pressure

Metallic Heads: 1500 psi (103 bar) @ 700 rpm

Maximum Inlet Pressure 250 psi (17 bar) with 1500 psi (103 bar) maximum discharge pressure
500 psi (34 bar) with 1200 psi (83 bar) maximum discharge pressure

Maximum Operating Temperature

Metallic Heads: 250 °F (121 °C) - Consult factory for correct component selection for temperatures from 160 °F (71 °C) to 250 °F (121 °C).

Maximum Solids Size 800 microns

Inlet Port 2-1/2 inch NPT
150lb or 600lb ANSI RF flange
3 inch SAE flange

Discharge Port 1-1/4 inch NPT
600lb or 1500lb ANSI RF flange
1-1/4 inch SAE flange

Shaft Diameter 2 inch (50.8 mm)

Shaft Rotation Reverse (bi-directional)

Bearings Tapered roller bearings

Oil Capacity 7.75 US quarts (7.3 liters)

Weight

Metallic Heads: 257 lbs. (116.6 kg)

Net Positive Suction Head (NPSHr)

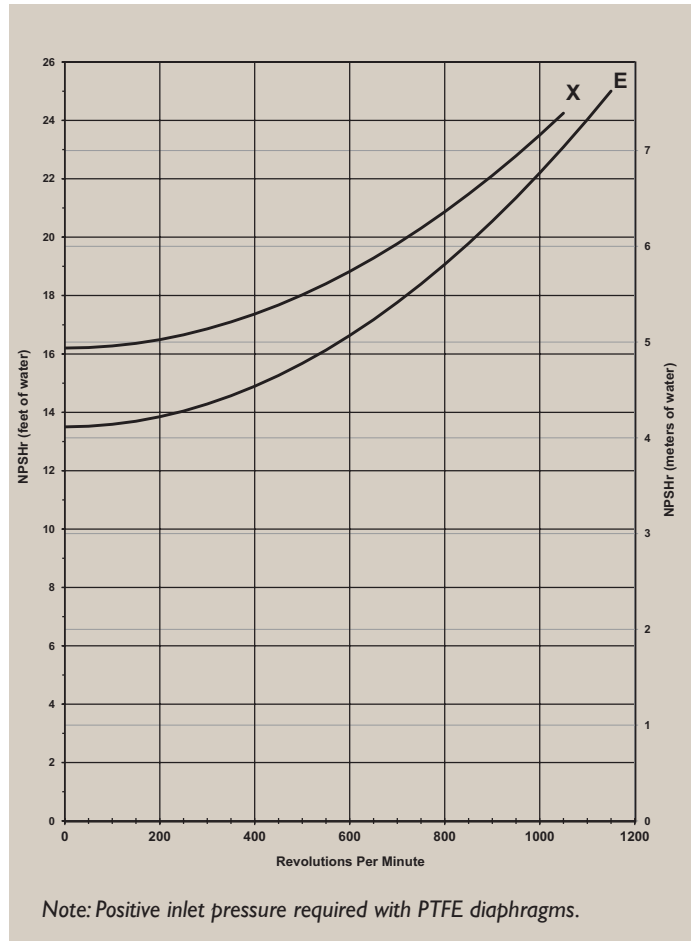

Self-priming:

Each Hydra-Cell pump has different lift capability depending on model size, cam angle, speed, and fluid characteristics. To ensure that your specific lift characteristics are met, refer to the inlet calculations regarding friction, and acceleration head losses in your Hydra-Cell Installation & Service Manual. Compare those calculations to the NPSHr curves above.

Calculating Required Power

$$\frac{100 \times \text{rpm}}{63,000} + \frac{\text{gpm} \times \text{psi}}{1,460} = \text{electric motor hp}$$

$$\frac{100 \times \text{rpm}}{84,428} + \frac{\text{l/min} \times \text{bar}}{511} = \text{electric motor kW}$$

When using a variable frequency drive (VFD) controller, calculate the hp or kW at minimum and maximum pump speed to ensure the correct hp or kW motor is selected. Note that motor manufacturers typically de-rate the service factor to 1.0 when operating with a VFD.

D35 Series Representative Drawings

D35 Models with NPT Inlet/Outlet Ports Inches (mm)

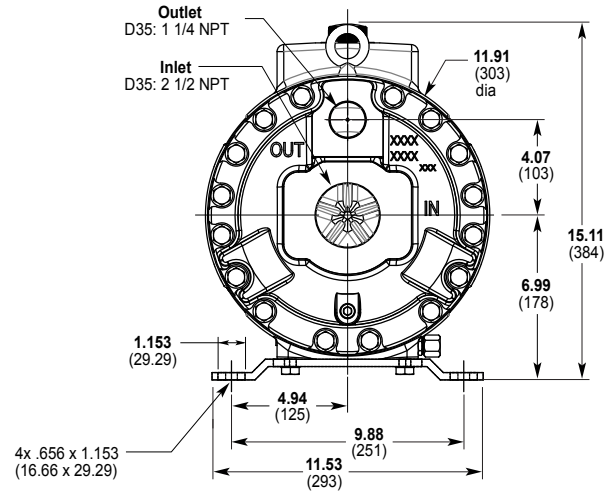
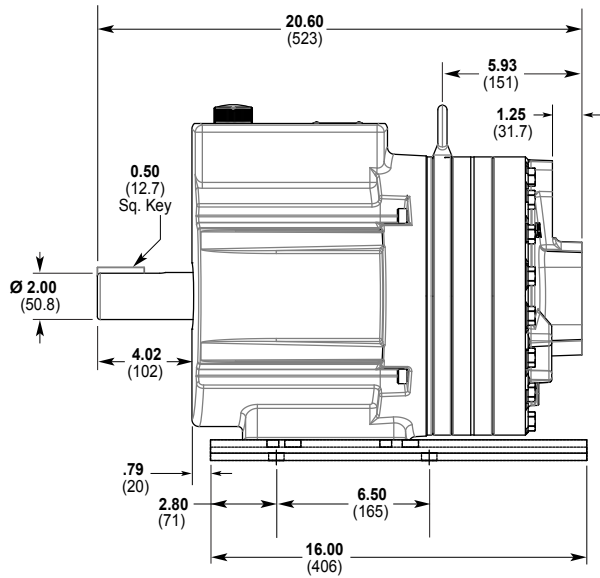

D35 Models with SAE Flange Inlet/Outlet Ports Inches (mm)

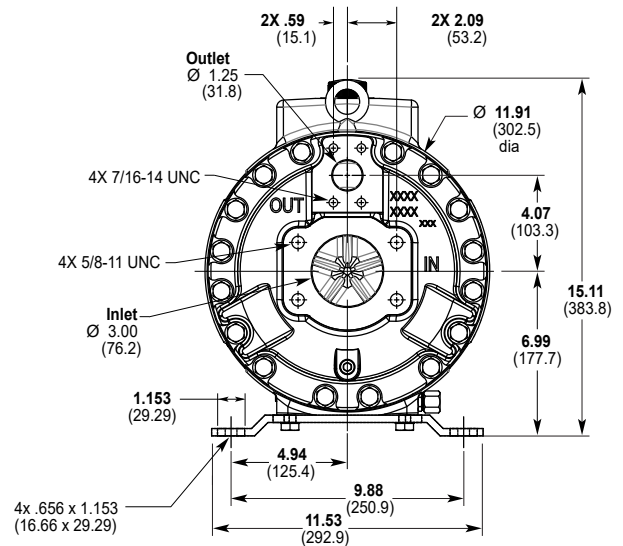
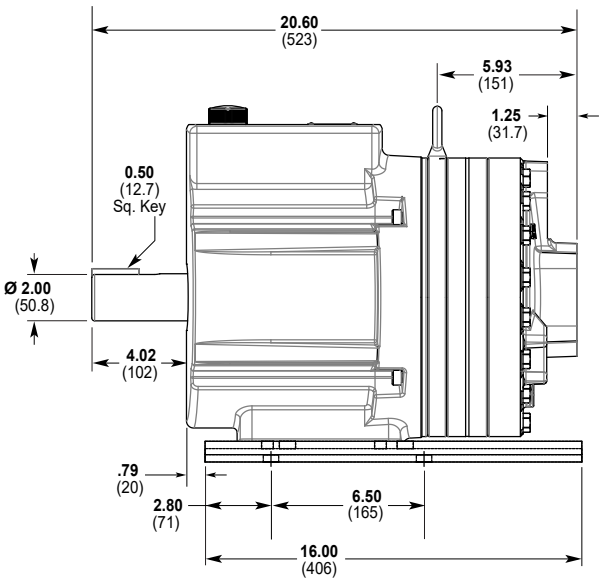

Note: Contact factory for additional drawings of specific models and configurations.

D35 Series Representative Drawings/Valves/Skids

D35 Models with ANSI Flange Inlet/Outlet Ports Inches (mm)

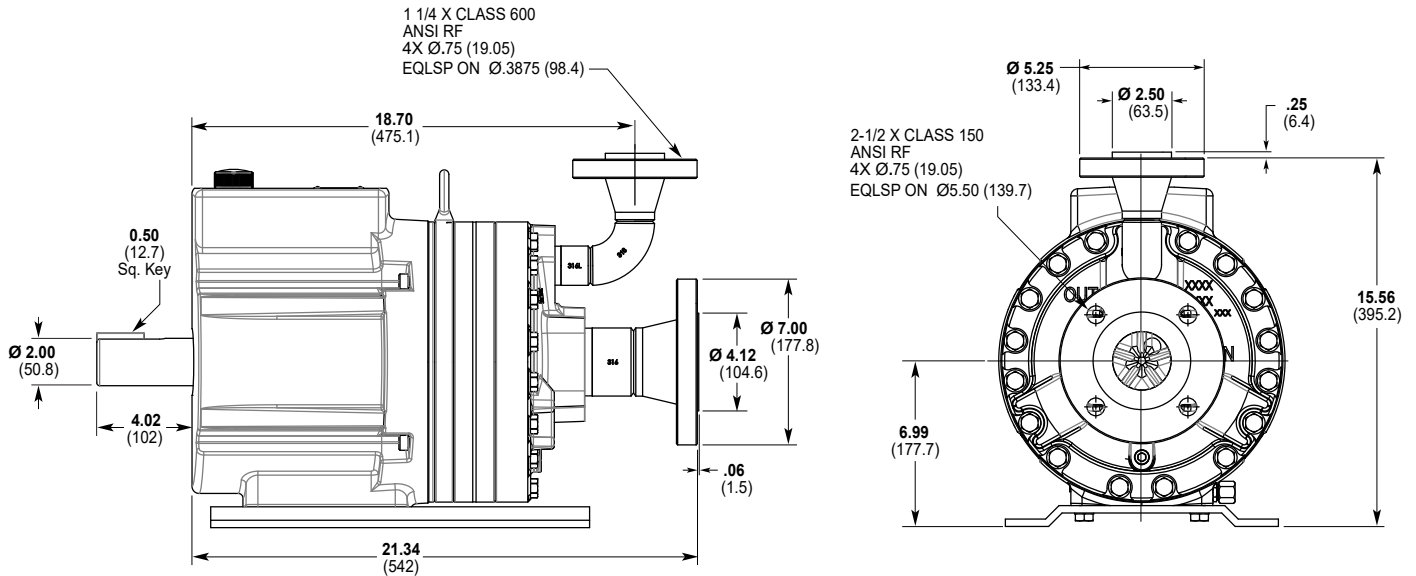

Note: Contact factory for additional drawings of specific models and configurations.

Valve Selection

A seal-less C64 Pressure Regulating Valve is recommended for Hydra-Cell D35 pumping systems, especially for high-pressure requirements or when handling dirty fluids.



A C24 Pressure Regulating Valve provides a capable, lower-cost alternative to C64 valves for Hydra-Cell D35 pumping systems.



Skid-mounted D35 with 20hp, 3-phase motor.



For complete specifications and ordering information, consult the Hydra-Cell Master Catalog.

D35 Series How to Order

Ordering Information

1	2	3	4	5	6	7	8	9	10	11	12
---	---	---	---	---	---	---	---	---	----	----	----

A complete D35 Series Model Number contains 12 digits including 9 customer-specified design and materials options, for example: D35XKBTHFECA.

Digit	Order Code	Description
1-3	D35	Pump Configuration Shaft-driven (NPT Ports or SAE or ANSI Flanges)
4	X E	Hydraulic End Cam Max 36.5 gpm (138 l/min) @ 1050 rpm Max 34.0 gpm (129 l/min) @ 1150 rpm
5	K E	Pump Head Version Kel-Cell NPT Ports or ANSI Flanges Kel-Cell SAE Flanges
6	B C G Q R S T	Pump Head Material Brass Ductile Iron (Nickel-plated) Duplex Alloy 2205 (with Hastelloy C followers & follower screws) 316L Stainless Steel ANSI flange class 600 x 1500 316L Stainless Steel ANSI flange class 150 x 600 316L Stainless Steel - threaded or SAE ports Hastelloy CW12MW
7	A E G J P T	Diaphragm & O-ring Material Atlas diaphragm / PTFE o-ring EPDM (requires EPDM-compatible oil - Digit 12 oil code D) FKM PTFE (available with E cam only; 1050 rpm max.) Neoprene Buna-N
8	C D H N T	Valve Seat Material Ceramic Tungsten Carbide (900 rpm max.) 17-4 Stainless Steel Nitronic 50 Hastelloy C
9	C D F N T	Valve Material Ceramic Tungsten Carbide (900 rpm max.) 17-4 Stainless Steel Nitronic 50 Hastelloy C

Digit	Order Code	Description
10	E H T	Valve Springs Elgiloy 17-7 Stainless Steel Hastelloy C
11	C H M P T Y	Valve Spring Retainers Celcon 17-7 Stainless Steel PVDF Polypropylene Hastelloy C Nylon (Zytel)
12	A B D E G H	Hydra-Oil 10W30 standard-duty oil 40-wt for continuous-duty oil (use with 316L SST or Hastelloy CW12MW pump head - standard) EPDM-compatible oil Food-contact oil 5W30 cold-temp severe-duty synthetic oil 15W50 high-temp severe-duty synthetic oil

D35 Pump Housing is standard as Cast Aluminum. Upgrade to Ductile Iron available.

Consult the Hydra-Cell Master Catalog for:

- Motors, bases, couplings and other pump accessories
- Hydra-Oil selection and specification information
- Design considerations, installation guidelines, and other technical assistance in pump selection

Hydra-Cell®

Seal-less Pumps

Wanner Engineering, Inc.

World Headquarters & Manufacturing

Wanner Engineering, Inc.
1204 Chestnut Avenue
Minneapolis, MN 55403 USA
Phone: 612-332-5681 • Fax: 612-332-6937
Toll-Free Fax (USA): 800-332-6812
Email: sales@wannereng.com
www.Hydra-Cell.com

Regional Office

207 US Highway 281
Wichita Falls, TX 76310 USA
Phone: 940-322-7111
Toll-Free: 800-234-1384
Email: sales@wannereng.com
www.Hydra-Cell.com

Latin American Office

R. Álvaro Anes, 150 Bairro Campestre
Santo André/São Paulo, Brazil - CEP 09070-030
Phone: +55 (11) 4081-7098
Email: mmagoni@wannereng.com
www.Hydra-Cell.com

Wanner International Ltd.

Wanner International, Ltd.
Hampshire - United Kingdom
Phone: +44 (0) 1252 816847
Email: sales@wannerint.com
www.Hydra-Cell.eu

Wanner Pumps Ltd.

Wanner Pumps, Ltd.
Kowloon - Hong Kong
Phone: +852 3428 6534
Email: sales@wannerpumps.com
www.WannerPumps.com

Shanghai - China
Phone: +86-21-6876 3700
Email: sales@wannerpumps.com
www.WannerPumps.com

