

# Magnet drive gear pump-motor units FG100 series

The Fluid-o-Tech® FG100 series, born from the long experience in mag drive external gear pumps, provides a smart and compact unit which finds easily its location in most machines. The pump housing is in stainless steel and the non-metallic parts have been selected to comply with the most strict sanitary requirements. The electromagnetic drive delivers a smooth transmission of the rotation, little or no noise and a leak free unit, while the integrated electronic allows for the 24V brushless DC heart of the FG100 to be controlled directly from the logic of the machine. Complete flexibility, dispense after dispense. The FG100 series combines the external gear pump technology taken to its perfection and a brushless DC motor in a rotor less configuration. This ensures a top performance with an exceptionally long service life.



## MAIN APPLICATIONS

- Espresso coffee machines
- Food processing equipment
- Laser apparatus
- Lubrication
- Medical equipment
- Cooling systems
- Laboratory instrumentation
- Water treatment



## TECHNICAL INFORMATION

Pump housing material	AISI 316L	Motor type	24V BLDC cw e ccw direction
Gears and bushing material	Peek	Speed range	from 500 to 5000 rpm
Ports	1/8" GAS	Max output power	60 W
Max static pressure	20 bar/290 psi	Motor IP protection	IP 52
Max vacuum	724 mmHg/28.5 inHg	Insulation class	F
Wet lift with water*	~ 8 m/26.2 ft	Unit weight	675 g/1.5 lb

\* Priming ability varies with operating conditions and fluid characteristics

## OPERATING RANGE

Max ambient temperature	40 °C/104 F	70 °C/150 F	40 °C/104 F
Fluid temperature	95 °C/203 F	55 °C/131 F	40 °C/104 F
Max torque	30 mNm/4.2 in-oz at 5000 rpm	70 mNm/9.9 in-oz at 3500 rpm	100 mNm/14.1 in-oz at 3500 rpm
Min ambient temperature		5 °C/41 F	

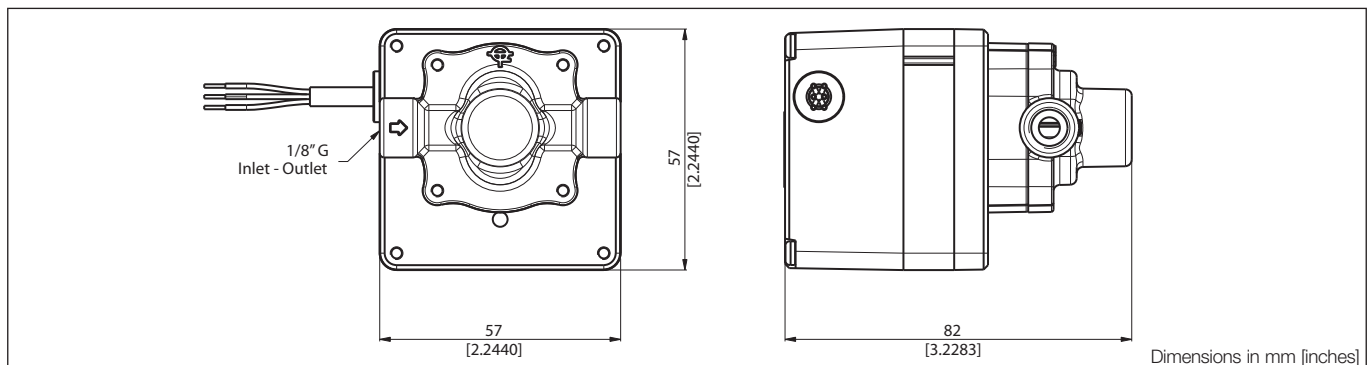

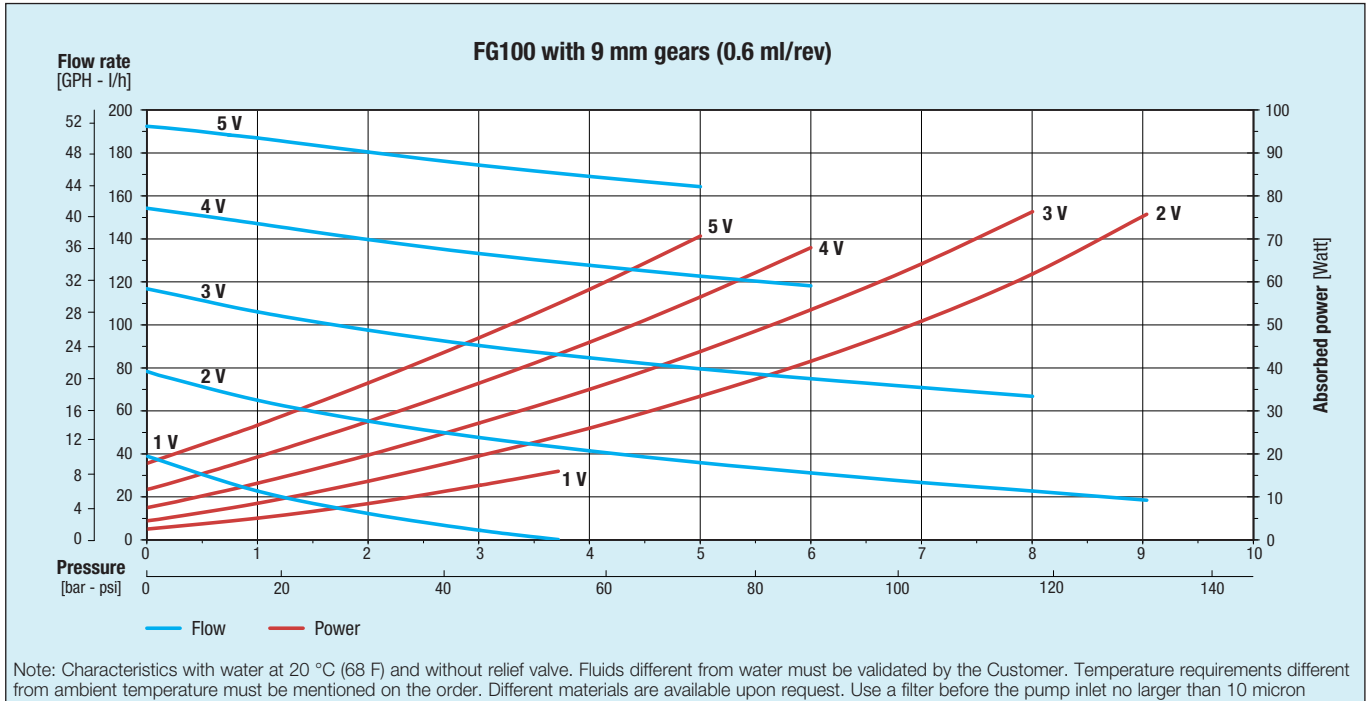

Fluid-o-Tech reserves the right to alter the specifications indicated in this catalogue at any time and without prior notice.

**Fluid-o-Tech srl**  
Via Leonardo da Vinci, 40  
20094 Corsico, Milano, Italy  
Tel. +39 02 9995 01  
Fax +39 02 9995 0999  
info@fluidotech.it

**Fluid-o-Tech Int'l Inc.**  
161 Atwater St.,  
06479 Plantsville CT (USA)  
Tel. +1 (860) 276 9270  
Fax +1 (860) 620 0193  
info@fluid-o-tech.com

**Fluid-o-Tech Int'l Inc. Japan**  
201, 4-3-10, Todoroki,  
Setagaya, Tokyo 158-082, Japan  
Tel. +81 (0) (3) 6432 1812  
Fax +81 (0) (3) 6432 1813  
erkkato@fluidotech.jp

**Fluid-o-Tech Asia (Beijing) Co., Ltd**  
Jingwei Industrial Zone,  
Beifang Huairou, Beijing, 101400, PRC  
Tel. +86 (0) (10) 6168 4650  
Fax +86 (0) (10) 6168 4651  
info@fluidotech-asia.com