

VISCOFLUX mobile Drum Emptying System



More than just pumps



New!

Now with new
process device
in stainless
steel

VISCOFLUX mobile

The stand-alone solution for transferring high-viscosity fluids

VISCOFLUX mobile is a portable and thus very flexible variant of the tried and tested VISCOFLUX drum emptying system. VISCOFLUX mobile is ideal for the gentle conveyance of high-viscosity, paste-like and non-free flowing materials, even from conical drums with aseptic bags. The system is especially suitable for the use in the field of Pharma Food Cosmetic and available for different drum diameters.

Functional description

VISCOFLUX mobile is a stand-alone system consisting of a process device and a pump unit comprising of a motor, pump and follower plate which is individually designed for each application. Steerable rear wheels on the trolley make it easy to move the system to the drum.

Before starting the transfer of the material, the pump unit is lowered by means of a rechargeable battery drive until the follower plate touches the material. Then the drive is uncoupled from the linear motion axis via electronic control and the pump motor is started. The self-priming eccentric worm-drive pump creates a vacuum below the follower plate which causes the follower plate to lower. This guarantees especially gentle transport of the medium. The flexible process seal adjusts even to beads and tapered constrictions, leaving almost no material on the drum wall. In this way, VISCOFLUX mobile achieves residual quantities of less than 1 % in the drum and less than 2 % if aseptic bags are used. Moreover, the process seal hermetically seals the medium and ensures process reliability even if the transferring process is interrupted. After transfer, compressed air lifts the follower plate off the bottom of the drum and pump unit simply moves out of the drum. When emptying drums with aseptic bags, the inliner is automatically kept close to the drum wall, at first by the medium and later, when the follower plate is moved out, by the compressed air. Due to the flexibility of the process seal, even drums which have suffered slight transportation dents can easily be emptied.

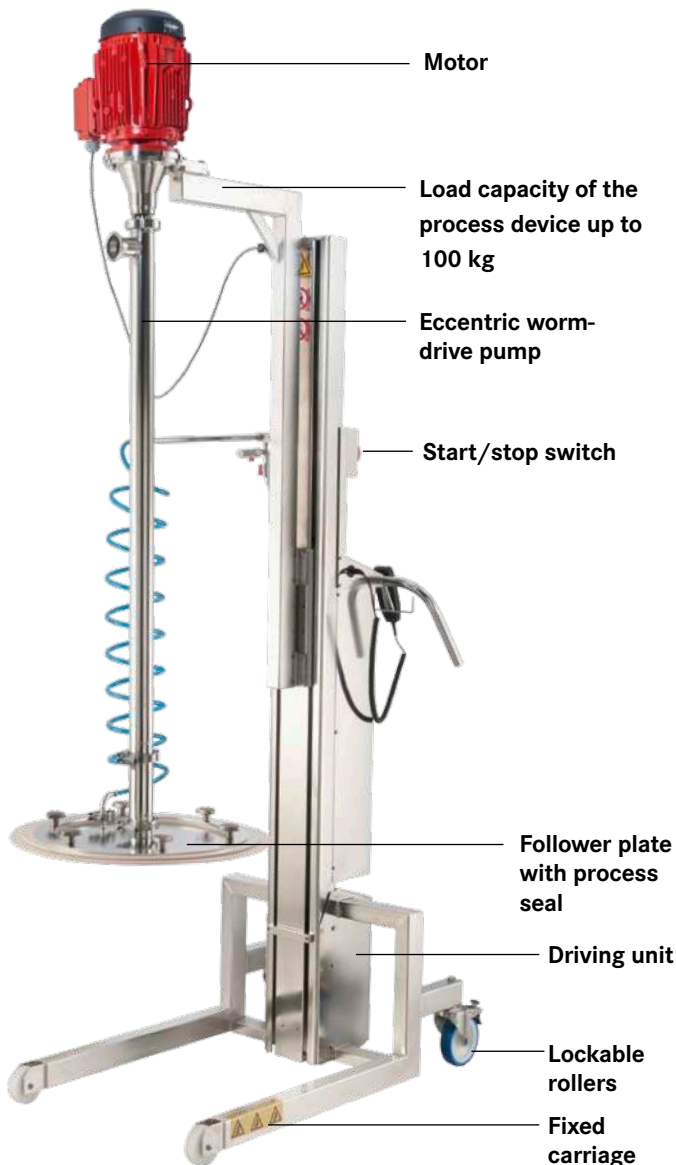

VISCOFLUX mobile, the drum emptying system.

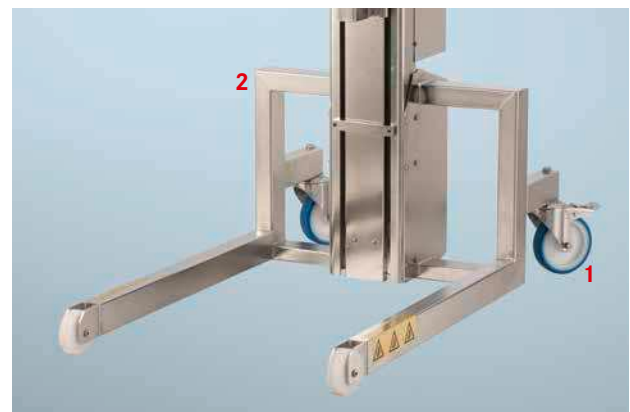

Process device developed to the applicable hygiene requirements

- 1: Plastic rolls of full material
- 2: All contacts welded

Product characteristics

- ▶ Stand-alone, mobile system due to integrated mobile process device
- ▶ Process device completely made of stainless steel, protection class IP 66
- ▶ Pump and follower plate can be dismantled quickly and completely
- ▶ Follower plate can be replaced with process seal
- ▶ Emptying with residual quantities of less than 1 % (in drums without inliner)
- ▶ Also suitable for drums suffering from the usual transportation dents
- ▶ Pump can be removed separately
- ▶ The system which works with a vacuum, ensures low-turbulence, gentle transport
- ▶ Pump unit consisting of pump, motor and follower plate can be individually adjusted to the medium using the process seal
- ▶ Follower plate with special process seal for conical drums
- ▶ Process seal available in FOOD version 
- ▶ Also suitable for drums with aseptic bags
- ▶ Also available for sea container drums

Examples of media

- ▶ Non-free flowing media
- ▶ Media with outgas or react with oxygen
- ▶ Greases up to grease class 3
- ▶ Media that must be free from air bubbles and foreign particles
- ▶ High-viscosity base and raw materials
- ▶ Tomato puree
- ▶ Paste-like condiments
- ▶ Fruit sauce
- ▶ Creams and ointments such as zinc oxide ointments
- ▶ Vaseline
- ▶ Hand cleaning pastes



Application film:
<http://www.flux-pumps.com/mobile/en/p0417.html>

General advantages

- ▶ **Mobile use**
Can be moved to the drum without a crane or fork-lift truck
- ▶ **Low space requirement**
Can be transported even in lifts
- ▶ **Easy in handling**
Decoupling via friction clutch and electronics. No tracking of additional sledges necessary.
- ▶ **Cost savings**
Efficient use of the medium and low expenditure for disposal
- ▶ **High process reliability**
due to hermetic sealing of the medium even if the transfer process is interrupted
- ▶ **Energy savings**
Usually no heating of the medium necessary
- ▶ **No structural change to the medium**
due to gentle, continuous transport
- ▶ **Easy cleaning**
Can be completely cleaned using a water jet
- ▶ **One transfer system for different drum types**
Also suitable for conical drums and for drums with aseptic bags
- ▶ **Also available in Food version** 
conform to Regulation (EC) 1935/2004 and FDA CFR 21
- ▶ **Resistant to aggressive cleaning agents**
completely made of stainless steel

Technical data

- ▶ Process device: Battery-operated, completely made of stainless steel, load capacity up to 100 kg, carriage in two standard sizes
- ▶ For drum diameters: 560 mm or 571 mm, for conical drums (550 mm at the top and 515 mm at the bottom)
for drums with small opening Ø 540 mm at the top, Ø 571 mm at the bottom
- ▶ Pumps: Ø 54 mm, length 1000 mm and 1200 mm
F 550 for industrial applications,
F 560 for Pharma Food Cosmetic applications, also with anticlockwise/clockwise rotation
- ▶ Motors: Three-phase motors from 0.75 kW, spur gear motors, compressed-air motors
- ▶ Process seal material: NBR or FKM
- ▶ Power supply for motor or switching cabinet
- ▶ Ventilation by two separate ball valves

VISCOFLUX mobile

Flexible, gentle and efficient

The stand-alone VISCOFLUX mobile system can quickly and easily be transported to the selected drum. The pump unit with the self-priming eccentric worm-drive pump guarantees especially gentle transfer of the fluid. The hermetically sealed follower plate provides high process reliability, enabling interruption of the transfer process.



VISCOFLUX mobile – for the gentle conveyance of high-viscosity, paste-like and non-flowable media.



VISCOFLUX mobile – continuous transport using the example of vaseline.



VISCOFLUX mobile – easy handling when filling in containers.



VISCOFLUX mobile – high process reliability even if the transfer process is interrupted.



VISCOFLUX mobile – easy handling, gentle transfer (example: Pharma Food Cosmetic version).



VISCOFLUX mobile – ideal for transfer out of conical drums with aseptic bags (example: tomato paste).



VISCOFLUX mobile – also suitable for “cardboard drums” since no additional pressure is required on the follower plate when emptying (here: caramel cream).

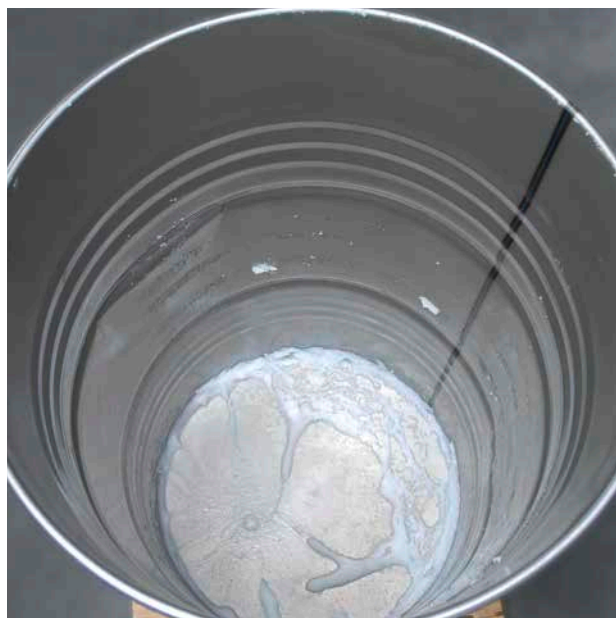

VISCOFLUX mobile – achieves residual quantities of under 1 % (in drums without inliner) – despite usual transportation dents.

Note

Further versions of the VISCOFLUX family (see separate brochures):

- ▶ The classic VISCOFLUX for the transport of high-viscosity media (transport to drum via crane or fork-lift truck)
- ▶ VISCOFLUX lite for transferring high-viscosity substances just capable of flowing

Special equipment options

For different branches and applications



VISCOFLUX mobile – with control unit and integrated FLUXTRONIC® for use in batch processing.

VISCOFLUX mobile provides a multitude of control options for emptying the drum.

For example, an end position cut-off can be integrated into the VISCOFLUX mobile drum emptying system. On reaching a pre-defined media level in the drum, the drive motor switches off automatically. External signals from a balance or a fill level measurement sensor can also be processed for use in batch processing. In this way, for example, the pump operation can be switched off and at the same time a solenoid valve closed, for example when reaching a certain filling weight. The filling of this preset quantity can also be triggered via an external start/stop switch. The control unit with integrated FLUXTRONIC® provides even more possibilities for batch processing. Here, the FLUXTRONIC® processes the incoming impulse signals from a flow meter or a speed sensor on the pump, and thus controls the switch-off of pump and solenoid valve on reaching the required filling quantity.



VISCOFLUX mobile – mobility across floors.



VISCOFLUX mobile - use for cardboard drums and europallets.

VISCOFLUX mobile

Mobile use, easy to clean



Due to its mobile process device, the VISCOFLUX mobile can be transported quickly and easily to the material to be transferred or to the cleaning area - even up and down storeys. This is because it can also be transported by lift due to its extremely compact construction. After use, the pump unit, consisting of motor, pump and follower plate, can be dismantled quickly for cleaning.

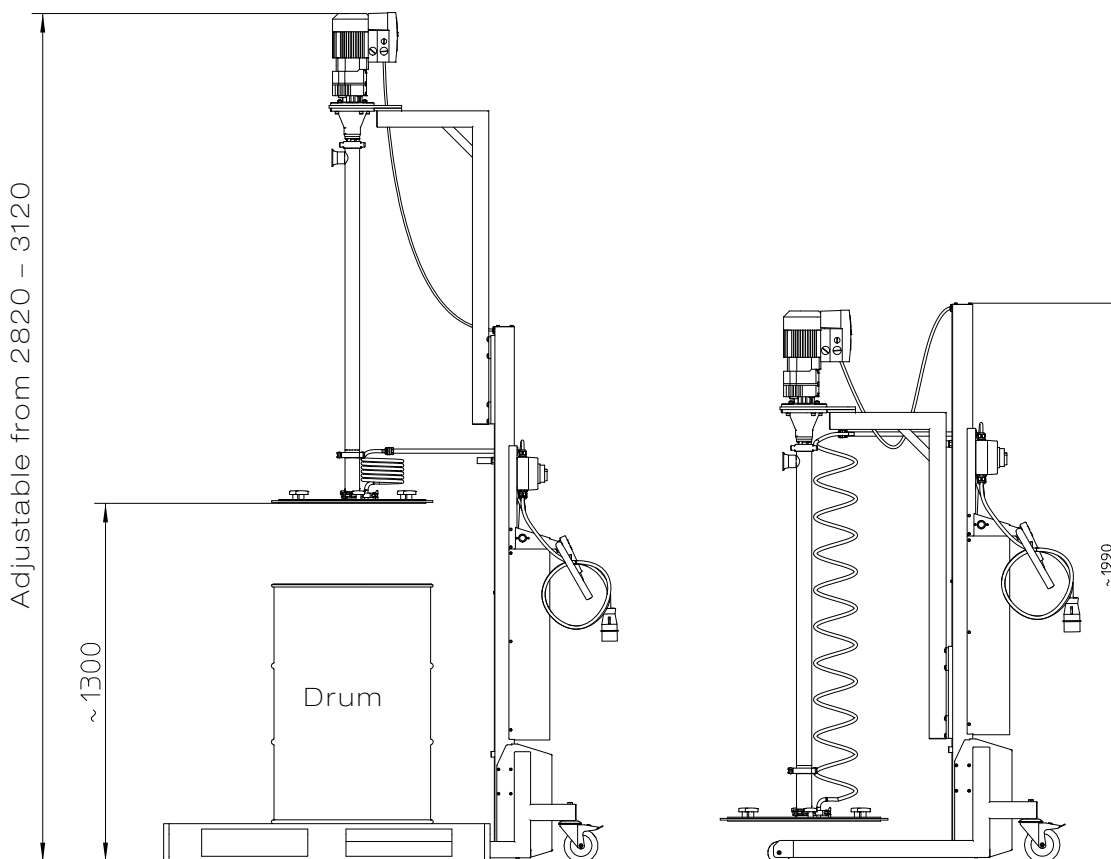

VISCOFLUX mobile - its size also gives it an advantage over other systems.

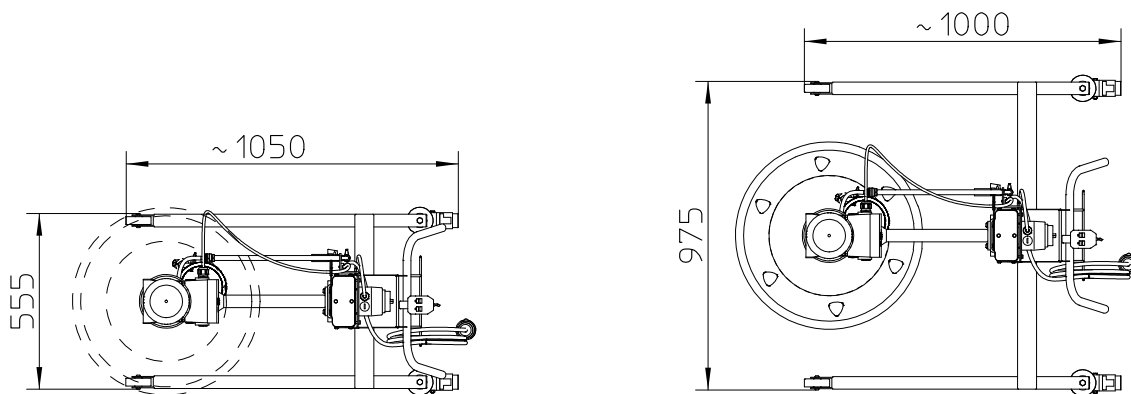

VISCOFLUX mobile - standard carriage for europallets.

VISCOFLUX mobile - standard carriage for drum dolly and special pallets.



More than just pumps

FLUX is a world renowned brand for the highest standards in pump technology. It all began in 1950 when the electric barrel pump was invented. Today, our wide range of products includes drum and container pumps, centrifugal immersion pumps, eccentric worm-drive pumps and air-operated diaphragm pumps as well as mixers, flow meters and, of course, an extensive range of accessories.

Apart from the outstanding quality of our FLUX products, our customers appreciate our staff's excellent expertise and real customer orientation.

Put us to the test. We are looking forward to hearing from you.